



## DESCRIPTION

The 10-2474-p, Supplemental Power Supply (SPS) provides an additional 2A Standby and 6A Alarm power for the system components. The power supply includes the SPS circuit board and a selectable secondary transformer (-1 for 120VAC primary; -2 for 240VAC primary), both of which are mounted within the control panel enclosure. The SPS circuit board is equipped with three additional auxiliary power output circuits, battery charging circuit and a dedicated AC power connection.

## COMPATIBILITY

The SPS is compatible with Fike's CyberCat™ 1016 Fire Alarm and the Cheetah Xi™ Fire Suppression control panels.

## SPECIFICATIONS

Power Consumption:  
4mA (standby), 40mA (alarm)

### P21 Terminal (removable):

#### AC XFMR Secondary

- Accepts 12-16 AWG
- Compatible Transformers:  
P/N 02-10881, 120 VAC, 60Hz @ 2.6 A; 250 VA or P/N 02-10882, 240 VAC, 50/60Hz @ 1.5 A; 348 VA
- Nonpower-limited and supervised
- Fused by F1; 15 A field replaceable fuse, P/N 02-4174
- 16 AWG THHN wiring minimum

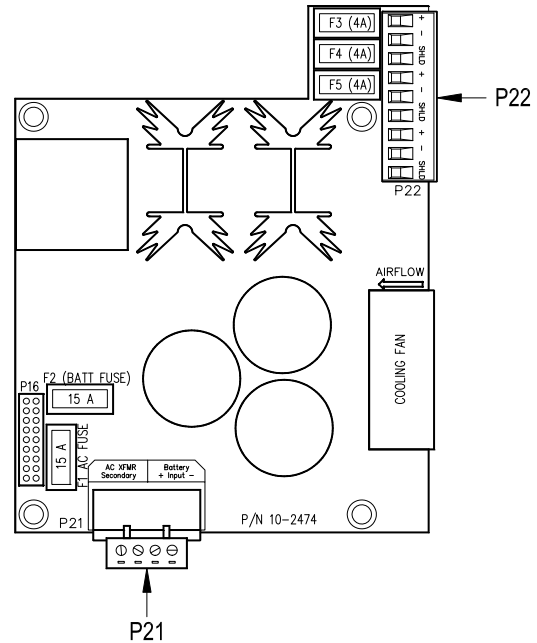
### P21 Terminal (removable):

#### Battery Input (+,-)

- 24 VDC nominal standby battery input
- Sealed lead acid batteries only
- 75 AH maximum charging capacity
- 4 A @ 27 VDC max. charge current
- 12 A @ 27 VDC max. supply current
- Non-power limited and supervised
- Fused by F2, 15 A field replaceable fuse, P/N 02-4174
- 14 AWG wiring minimum

### P22 Terminal (removable):

- Auxiliary Outputs (+,-,shld)
- Accepts 12-24 AWG
- Three continuous, regulated auxiliary power outputs rated 2 A @ 24 – 28 VDC maximum
- Power limited and supervised
- Fused by F4 and F5 for short circuit; 4 A field replaceable fuse, P/N 02-11412



**Exhibit 1 Supplemental Power Supply (SPS)**

## SPECIFICATIONS - CONTINUED

### Dimensions (LxWxD):

4.5" x 5.5" x 2"  
(11.43cm x 13.97cm x 5.08cm)

### Weight:

Circuit Board	0.66 lbs. (299 grams)
Transformer	7 lbs. (3.18 kilograms)

Operating Temp: 32°F to 120°F (0°C to 49°C)

Operating Humidity: 93% RH, non-condensing

## OPERATION

The SPS monitors the AC power and battery connections and will transmit a trouble condition to the system control board upon loss of AC or battery power. In the event of AC power loss, the SPS will provide a smooth transition to batteries. The SPS performs ground fault testing and is capable of charging up to 75 AH batteries.

**Note:** The Optional SPS provides a common power bus between the main controller and SPS. Since power is shared through this bus, the standby battery power can be installed on either supply or split between them (Maximum of 75 AH for each charger).

## SPARE PARTS

10-2474 SPS Circuit Board only

02-10881 Transformer, 120VAC  
(included with -1 option)

02-10882 Transformer, 240VAC  
(included with -2 option)

02-11127 Terminal Block, 4 position for P21

02-10996 Terminal Block, 9 position for P22

02-4174 Fuse, 15Amp, Mini Auto, Fast Acting

02-11412 Fuse, 4 Amp, Mini Auto, Fast Acting

02-2715 Standoff, 0.625 M/F

02-1589 Screw, 6-32 x 0.375 Phillips

02-1361 Hex Nut, #6-32

4153-142 Lock Washer, #6

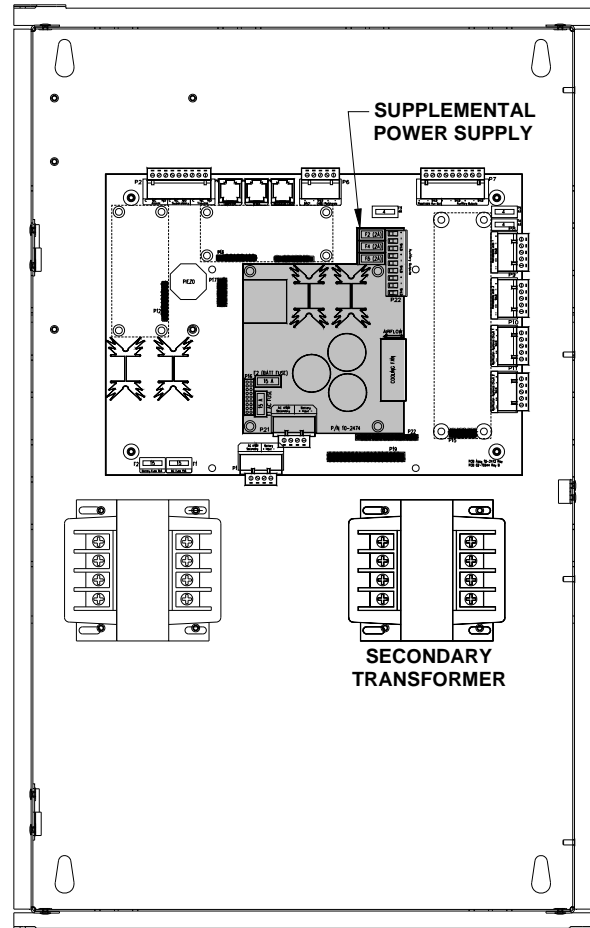
## PROGRAMMING

The SPS must be added to the control panel configuration to enable module and battery supervision. The configuration changes can be made using the panel's configuration menus or using the C-Linx system programming software. Refer to the associated control panels programming manual or the C-Linx "Users Guide", P/N 06-448 for programming details.

## INSTALLATION

Installation and wiring should be performed by qualified personnel only. Equipment damage and/or malfunction may result from improper installation. Remove all power from the system until the installation is complete and ready for testing.

1. Carefully unpack the SPS module and transformer and check for shipping damage.
2. Locate the four press-studs just to the right of the main transformer (See Exhibit 2) and install the secondary transformer onto the press studs. Secure transformer in place with four 6-32 hex nuts and washers supplied with SPS module.
3. Remove the main controller if already installed in the back-box by disconnecting the field removable terminal blocks; then remove the four hex nut/lock washers located in each corner of the board.

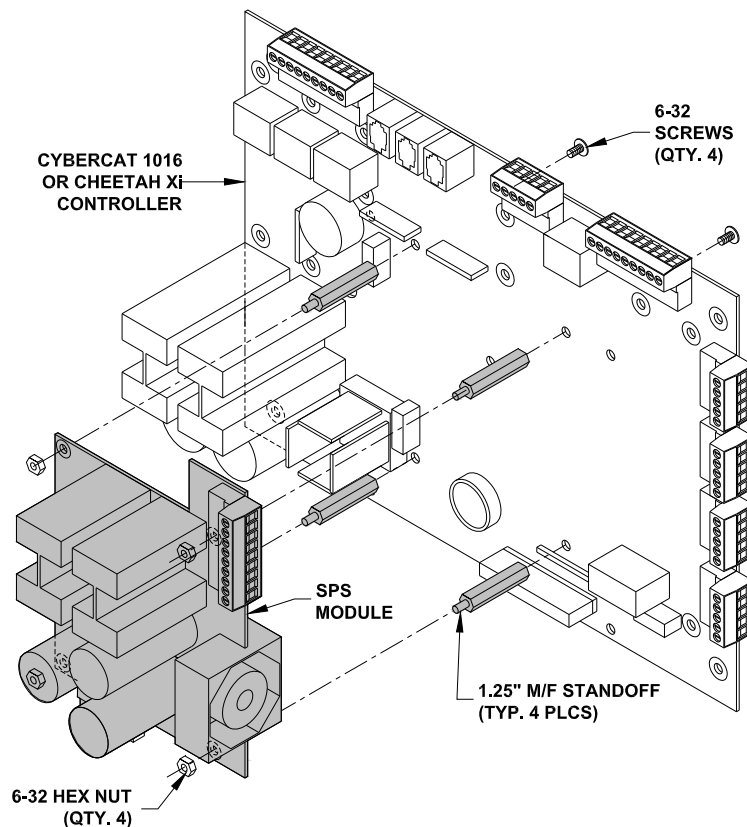


**Exhibit 2 SPS and Transformer Installation**

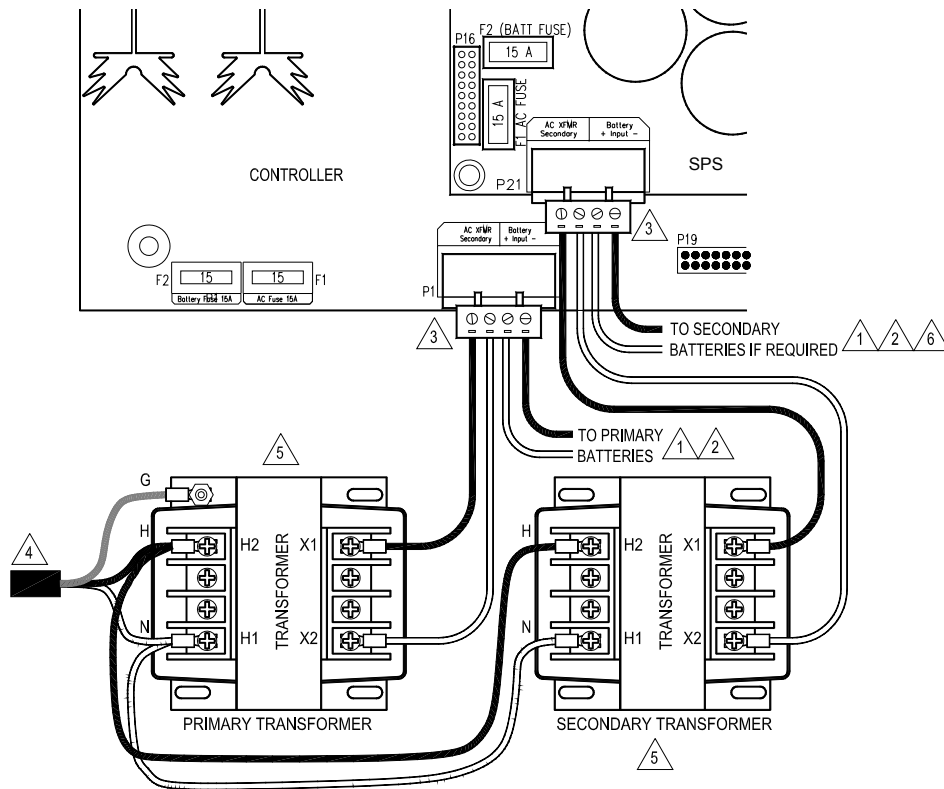
### **⚠ Caution**

The panel electronics contain static sensitive components. Handle the electronics by the edges only and avoid touching the integrated components. Keep the electronics in the protective static bag it was shipped in until time for installation. Always ground yourself with a proper wrist strap before handling the module(s). If the installer is properly grounded at all times, damage due to static discharge will not occur. If the module requires repair or return to Fike, it must be shipped in an anti-static bag.

4. Temporarily remove the display from the main control board by removing the four (4) screws from the front of the display board. Leave display cables P19 & P22 connected during SPS installation.
5. Secure the M/F standoffs supplied with the SPS module to the main controller by threading the four 6x32 screws with lock washer through the back of the main board into the femal end of the standoffs (See Exhibit 3). Make sure that the screws are not making contact with any of the electronic components on the main control board.
6. Insert the SPS module onto the standoffs making sure that the P16 header pins and standoff holes are properly aligned.
7. Secure the SPS module to the standoffs using the #6 lock washers and hex nuts provided.
8. Install wires from the primary transformer H1 & H2 terminals over to the secondary transformer H1 & H2 terminals (See Exhibit 4).
9. Install wires from the primary transformer X1 & X2 terminals to the P21 Secondary Transformer terminals on the SPS module (See Exhibit 4).
10. Install wires from the secondary set of batteries (if applicable) to the P21 Battery Input terminals on the SPS module (See Exhibit 4).
11. Remove the P21 terminal block from the SPS module and connect the AC power and battery wires to the appropriate terminals (See Exhibit 4).
12. Apply power (AC followed by DC) to the main controller first; then apply power to the SPS module by reinstalling the P21 connector to the module.
13. Verify that both the controller and the SPS module power up correctly. Immediately power down the system (DC followed by AC) if the display shows improper characters, you smell smoke, or if you see sparks. Investigate and correct the source of the malfunction prior to reapplying power.
14. Re-attach the display to the main control board using the four (4) screws removed in step 4.
15. Remove terminal P22 from the SPS module and connect the auxiliary power wiring from field devices to the appropriate terminals (See Exhibit 5). Make sure to observe correct wiring polarity.
16. Reinstall the P22 connector to the SPS module to power up field devices.

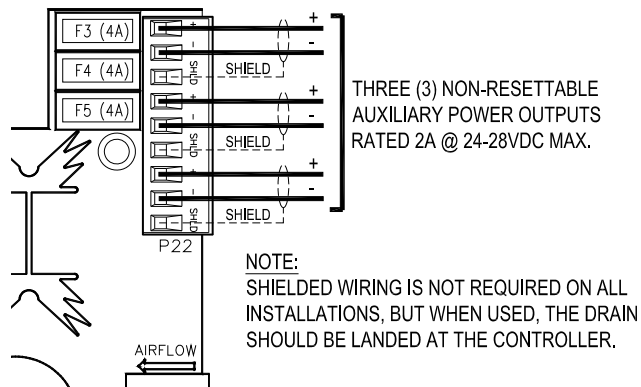


**Exhibit 3 SPS Mounting**



- NOTES:
1. USE 14 AWG MINIMUM WIRE WITH A MAXIMUM LENGTH OF 10 FT. (3 m) TO CONNECT BATTERIES TO CONTROLLER.
  2. BATTERIES LARGER THAN 18 AH MUST BE MOUNTED IN AN EXTERNAL BATTERY ENCLOSURE.
  3. IT IS CRITICAL THAT AC LINE POWER IS APPLIED TO LEFT TERMINALS OF P1 AND P21, NOT TO THE BATTERY TERMINALS. DOING SO COULD CAUSE DAMAGE TO THE CONTROLLER.
  4. SYSTEM AC LINE POWER MUST ORIGINATE FROM A DEDICATED CIRCUIT AT THE MAIN BUILDING POWER DISTRIBUTION CENTER. THE CIRCUIT BREAKER SHALL BE EQUIPPED WITH A LOCKOUT MECHANISM AND SHALL BE CLEARLY LABELED AS A "FIRE PROTECTION CONTROL CIRCUIT."
  5. IT IS CRITICAL THAT THE TRANSFORMER PRIMARY (H1 AND H2) AND SECONDARY (X1 AND X2) ARE NEVER SWAPPED BY CONNECTING AC FEED TO THE SECONDARY TERMINALS. DOING SO WILL CAUSE THE TRANSFORMER TO STEP-UP THE POWER RESULTING IN CERTAIN DAMAGE TO THE CONTROLLER.
  6. SECONDARY BATTERIES CONNECTED TO SPS MUST BE MOUNTED IN AN EXTERNAL BATTERY ENCLOSURE.

**Exhibit 4 SPS and Secondary Transformer Wiring Diagram**



**Exhibit 5 SPS Auxiliary Output Wiring Diagram**