

IMPULSE RELEASE MODULE (P/N 10-2748)

Important Notices

1. Please read the instructions carefully! Fike products are used for the protection of life and critical assets if installed and tested as described in this document.
2. Do not use Fike products for any application for which it is not intended. Fike shall not be in any way liable for any damages or losses incurred by you or third parties arising from the use of any Fike product for which the product is not intended by Fike.
3. Do not use Fike products described in this document outside of the ranges specified by Fike. Fike shall have no liability for malfunctions or damages arising out of the use of Fike products beyond such specified ranges.
4. Fike reserves the right to change product designs or specifications without obligation and without further notice.
5. This document is subject to Fike's full disclaimer at <http://www.fike.com/disclaimer>.
6. Visit www.fike.com to contact us or to download the latest version of this document.

Specifications

Current	+24V Supervisory: 20.0 ma (capacitor charging) 3.0 ma (capacitor is charged) -24V Activated: -37.0 ma (LED active)
Temp	32°F to 130°F (0°C to 54.4°C) 93% maximum humidity
Module Wiring	Control panel to IRM connections are supervised and power-limited Actuator connection to the IRM (IVO terminals) is supervised and power-limited
Mounting	4-inch square electrical box minimum 2-1/8" deep. Requires two-gang cover plate (components supplied by others)
Compatible Actuators	02-12728 - Impulse Valve Operator (IVO) 70-374 - Impulse Energetic Actuator (IEA)* IG71-247 - Universal Energetic Actuator (UEA)* *UL Listed only

Compatible Releasing Panels/Modules

The IRM can be used in conjunction with the control panels and modules shown in the table below. The table also shows the maximum number of IRM's that can be connected to the releasing circuit of the respective control panel or releasing module.

Releasing Device	IRM's per Circuit	EOLR Value
SHP-Pro	6	2.4KΩ
Cheetah Xi - RCM Module	6	2.7KΩ
Cheetah Xi 50- RCM Module	6	2.7KΩ

STOP WARNING

Any attempt to interface the IRM with a device not listed in the previous table could result in damage to the module, improper operation or serious personnel injury.

Dimensions

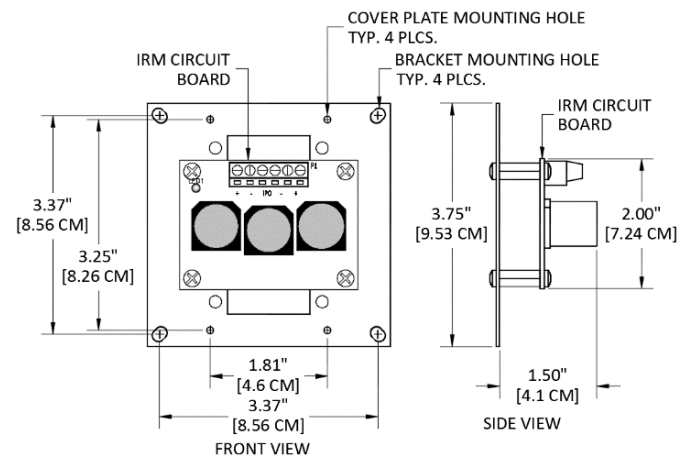

Figure 1 - IRM Configuration

Installation

Only factory trained service technicians who are authorized to work on this product shall install the IRM. The installer should thoroughly read and understand the instructions contained within this document before attempting to install the IRM. These instructions must be strictly followed to avoid potential damage to the module itself or inadvertent operation of the associated suppression container.

CAUTION

The IRM circuit board contains static sensitive components. Handle the electronics by the edges only and avoid touching the integrated components. Keep the electronics in the protective static bag it was shipped in until time for installation. Always ground yourself with a proper wrist strap before handling the module(s). If the installer is properly grounded at all times, damage due to static discharge will not occur. If the module requires repair or return to Fike, it must be shipped in an anti-static bag.

1. Power down the host control panel.
2. Mount the 4-inch square electrical box (supplied by others) to the wall with suitable anchors. The IRM must be located in the same room within 36 in. (91.4 cm) of the suppression system cylinder.
3. Install conduit and releasing circuit wiring in accordance with the project drawings and appropriate wiring diagrams. All wiring must conform to the requirements of NFPA 70 - National Electrical Code, NFPA 72 - National Fire Alarm Code, and the requirements of the Local Authority Having Jurisdiction (AHJ).

NOTE NFPA 2001 requires all initiating and releasing circuits to be installed in raceways.

4. Unpack the IRM from its packaging and inspect for damage. **Do not attempt to install the IRM if module shows signs of damage.**
5. Connect releasing circuit wires to the associated releasing control panel or module observing correct wiring polarity, as shown in Table 1.

Releasing Panel or Module Polarity	IRM Polarity	Wiring Options
SHP-Pro	+	Class A or B
Cheetah Xi & Xi 50 (RCM Module)	+	Class B
	-	

Table 1 - Releasing Circuit Wiring Polarity (Supervisory state)

NOTE NFPA 2001 requires the installation of a disconnect switch (Fike P/N 10-2698 and 10-2699) on an electrically actuated clean agent system to prevent unwanted discharge during system service or testing. Refer to Fike document 06-472 for switch installation. Switch is not shown in this document.

6. Connect the releasing circuit wiring to the IRM module(s) as shown in Figure 2 or Figure 3.

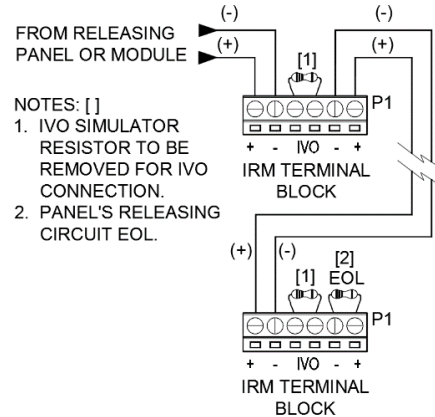

Figure 2 - Class B Wiring

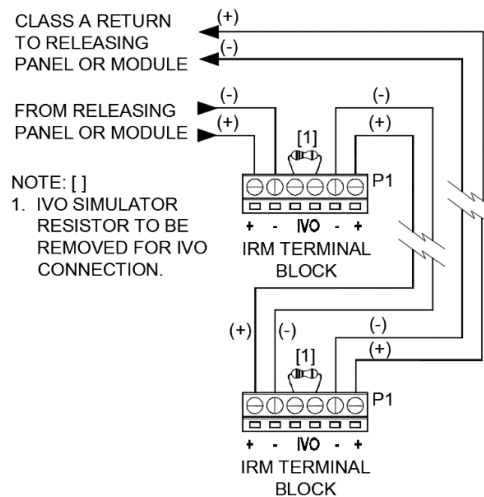

Figure 3 - Class A Wiring

7. Apply power to the releasing panel and check that the system is clear of any Troubles, and that the LED on the IRM is **not** illuminated.

If the LED is illuminated and the panel is not in the Release State, check the circuit wiring for proper polarity. Correct any wiring problems before proceeding.

CAUTION

If the IRM LED is illuminated, **DO NOT** connect the actuator wire leads to the module. This condition will cause the actuator to activate.

Acceptance Testing

The system releasing functions shall be thoroughly tested in accordance with the requirements of NFPA 72, National Fire Alarm and Signaling Code, requirements of the Local Authority Having Jurisdiction (AHJ), and the following requirements prior to connecting actuators to the IRMs:

1. Temporarily remove the end-of-line resistor from the last IRM on a Class-B circuit (See Figure 2) or disconnect the Class-A return wire leg on the last IRM (See Figure 3) and verify that a Trouble signal is received by the releasing panel.
2. Reinstall the EOL to the IRM or reconnect the Class-A wiring to the releasing panel.
3. Verify that the releasing panel returns to normal operation.
4. Remove the IVO simulator resistor from each IRM, one at a time, and verify that a Trouble signal is received by the releasing panel for each IRM.
5. Connect an Output Analyzer, P/N 10-2983 to the IVO terminals on the first IRM for testing (See Figure 2 or 3).
6. Place the system into the "Release" state to test the output current supplied by the IRM. Refer to Fike document 06-905 for instructions on how to use the Output Analyzer.
7. Verify that the LED on the IRM turns on to indicate it is in the active state.
8. Replace any IRM that does not pass the Output Analyzer testing.
9. Disconnect the Output Analyzer from the IRM and reinstall the IVO simulator resistor removed in step 4.
10. Repeat steps 5 through 9 for each IRM.
11. Verify that the IRM(s) does not activate during any state other than Release for the programmed zone.

Arming the System

Upon completion of the acceptance testing, the suppression containers can be armed using the following instructions:

1. Reset the releasing panel and verify that the panel is in the "NORMAL" no events present state.
2. Verify that the LED on each IRM is turned off indicating the module is NOT in the fired (active) state.

STOP WARNING

DO NOT connect an IEA or UEA to the IRM if the module LED is illuminated. This will result in actuation of the device.

3. Verify that the actuator is disconnected from the suppression container.
4. Remove the IVO simulator resistor installed on the IVO terminals of the IRM. Panel will go into Trouble to indicate the open circuit.
5. Connect the wire leads from the actuator (IVO, IEA or UEA) to the IRM terminals labeled IVO, as shown in Figure 4 and Figure 5.

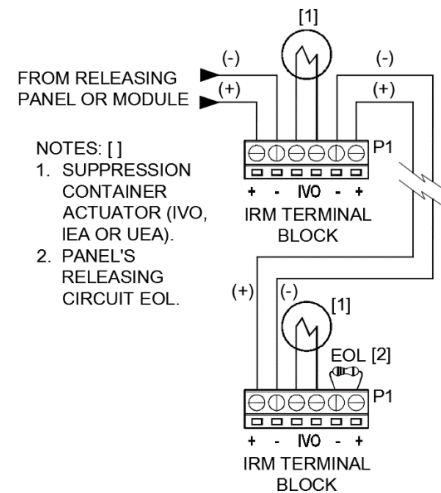

Figure 4 - Class B Wiring - Actuator Connected

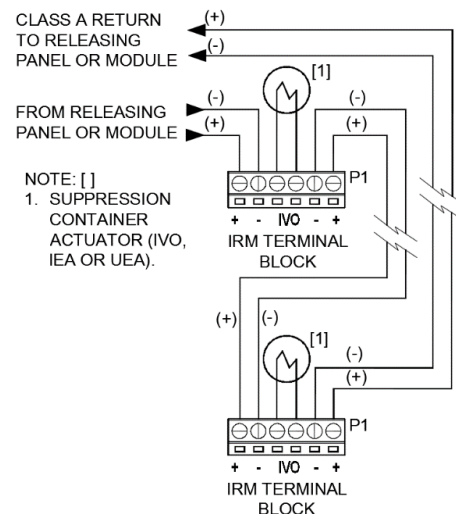

Figure 5 - Class A Wiring - Actuator Connected

6. Repeat steps 2 through 4 for each IRM.

Completing the Installation

1. Secure the IRM bracket to the electrical box using the screws provided, as shown in Figure 6. Make sure wiring is not pinched or excessive strain is not placed on the IRM terminal block.

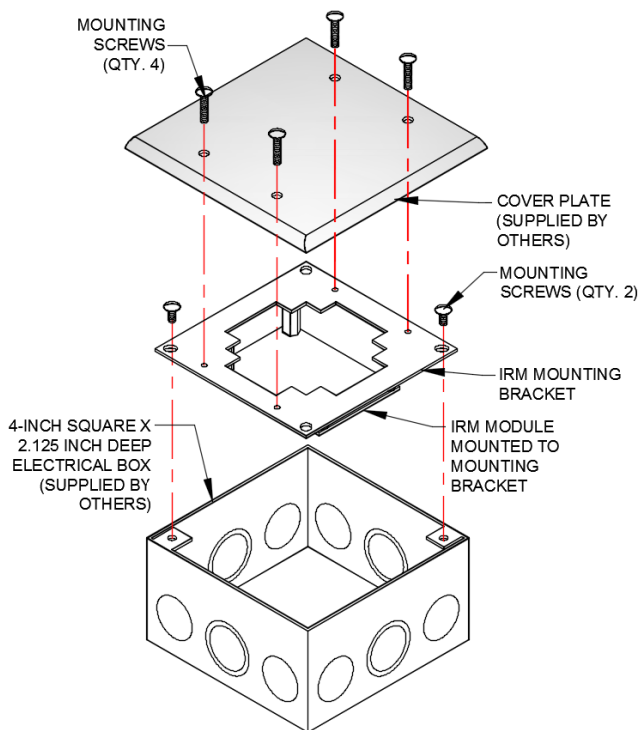

Figure 6 - IRM Installation

2. Install the blank cover plate (supplied by others) to the IRM mounting bracket using the screws provided with the plate, as shown in Figure 6.
3. Install the IRM identification label (P/N 02-12760), shown in Figure 7 onto the cover plate.



Figure 7 - IRM Identification Label

4. Connect the actuators to the suppression containers to arm the suppression system.

STOP WARNING

If there are ground faults present on the control system, **DO NOT** connect the actuator(s) to the suppression container. Doing so could result in accidental agent discharge.

STOP WARNING

Verify that the actuator has **NOT** been fired or has been reset before attempting to connect it to the suppression container. **DO NOT** attempt to connect any actuator to the suppression container if the firing pin is in the extended position.