

CIE-A-200

FIRE DETECTION SYSTEM



Fire Detection & Alarm System Control Panel (Suitable for Sita Devices)

26-1746 Issue 1

Fike[®]

SOLUTIONS

- / Fire Protection
- / Explosion Protection
- / Overpressure Protection
- / Pressure Activation

Fike's policy is one of continual improvement and the right to change a specification at any time without notice is reserved. Whilst every care has been taken to ensure that the contents of this document are correct at time of publication, Fike shall be under no liability whatsoever in respect of such contents.

Due to the complexity and inherent importance of a life risk type system, training on this equipment is essential and commissioning should only be carried out by competent persons.

Fike cannot guarantee the operation of any equipment unless all documented instructions are complied with, without variation.

E&OE.

Multipoint, Fike and Fike Corporation are registered trademarks of Fike Corporation and its subsidiaries. All other trademarks, trade names or company names referenced herein are the property of their respective owners.

Fike equipment is protected by one or more of the following patent numbers: GB2426367, GB2370670, EP1158472, PT1035528T, GB2346758, EP0917121, GB2329056, EP0980056, GB2325018, GB2305284, EP1174835, EP0856828, GB2327752, GB2313690

© 2018 Fike Safety Technology Ltd. All rights reserved. Document revised March 2020

Contents

Introduction	6
System Design.....	6
Equipment Guarantee	6
Anti-Static Handling Guidelines	6
Warning	6
EMC.....	6
The CIE-A-200 System.....	7
Advantages of Addressable Systems.....	7
Control Panel	8
Mounting the Control Panel	8
The General Assembly with front door removed.....	8
Control Panel Disassembly	9
Physical Dimensions	9
Cabinet Installation	10
Surface Mounting	10
Flush Mounting	10
Cable Entry.....	11
Mounting Data	11
Control Panel Assembly	11
Addressable Circuit Wiring.....	12
Topology & Cabling	12
Cable Specification.....	12
Loop Loading.....	13
General System Schematic.....	14
Control Panel Main PCB - Control & Indicating Equipment (CIE).....	15
Panel Backplane Layout.....	16
Peripheral Bus (PB_1 & PB_2).....	17
Monitored Inputs (MON_IN_1 & 2).....	18
Relay Outputs 1, 2 & Fault Relay Volt Free Contacts: NO, NC, COM.....	20
Addressable Loop: END1+, END1-, SCRN, END2+, END2-, SCRN.....	21
Auxiliary Power: 30V, 0V, SCRN.....	22
32V Power Input.....	23
CIE door USB Port: User_USB	24
Back Board ENG LOOP USB Port.....	24
Mains Supply & Batteries	25
Fuses 1 and In Line Battery Fuse	26
Battery Temperature Probe.....	27

General Operation of Control Panel	28
Control Panel Front	28
LED Indication.....	29
Fire Alarm Controls	30
System Controls.....	31
User	31
Supervisor.....	31
Engineer.....	31
Access Levels and Codes	32
Access Level 0 (Normal): Controls Enabled LED off.....	32
Access Level 1 (User): Controls Enabled LED on.....	33
Access Level 2 (Supervisor): Controls Enabled LED flashing slowly.....	34
Access Level 3 (Engineer): Controls Enabled LED flashing quickly	40
Alarm Confirmation Technology	45
Alarm Confirmation Delay.....	46
Selecting the Devices	46
Commissioning.....	47
Installation 1 st Stage	47
Installation 2 nd Stage.....	47
Initialisation	47
Commissioning	48
Configuration Example	49
End User Training.....	49
Good Practice	50
Number of Devices	50
Label the Loop Ends.....	50
Note the Loop Readings.....	50
Configuration Printout and Drawings.....	51
Initialisation.....	52
Normal Readings	52
Initialisation Process	52
Initialisation Faults	54
Earth Faults.....	56
General	56
General Fault Finding.....	57
Common Faults.....	57
Intermittent and Recurring Faults	58
IMPORTANT NOTE.....	59
Advanced Connections	60
Monitored Relays.....	60

Technical Data	61
Control Panel	61
Control Panel Fuses and Protection	62
Resistor Colour Codes	62
Battery Calculations	62
Installation Checklist	63
Stage 1	63
Stage 2	63
Commissioning Checklist	64
Step 1	64
Step 2	64
Step 3	64
Step 4	64
Loop Continuity and Insulation Test Results	65
FIRE ALARM SYSTEM NOTICE	66
To Enable the Control Panel Keypad	66
To Manually Operate the Fire Alarm Sounders	66
Following a Detector or Manual Call Point Operation	66
Following a Fault Condition	66
To Test the Indication LEDs	66
To Disable the Control Panel Keypad	66
Important Notes	66
Device Details	68
Engineers Notes	69
Index	72
Important Points	72

Introduction

This Manual is intended as a guide to the engineering and commissioning principles of the CIE-A-200 Addressable Intelligent Fire Alarm and Detection system, and covers the system hardware information only.

Due to the complexity and inherent importance of a system covering a 'Life Protection Risk', training on this equipment is essential, and commissioning should only be carried out by competent and approved persons. For further details of the availability of commissioning services contact your supplier.

System Design



This document does not cover Fire Alarm system design, and a basic understanding is assumed.

Knowledge of the current BS5839: Pt 1 Fire Detection and Alarm Systems for Buildings is essential.

It is strongly recommended that a suitably qualified and competent person is consulted in connection with the Fire Alarm System design and that the entire system is commissioned in accordance with the current national standards and specifications.

Equipment Guarantee



The equipment carries no warranty unless the system is installed, commissioned and serviced in accordance with this manual and the relevant standards by a suitably qualified and competent person or organisation.

Anti-Static Handling Guidelines



Immediately prior to handling any PCBs or other static sensitive devices, it is essential to ensure that a personal **connection to earth is made with an anti-static wrist-strap** or similar apparatus.

Always handle PCBs by their sides and avoid touching any components. PCBs should also be stored in a clean dry place, which is free from vibration, dust and excessive heat, and protected from mechanical damage.

Warning



Do not attempt to install this equipment until you have fully read and understood this manual.

Failure to do so may result in damage to the equipment and could invalidate the warranty.

Technical support will not be available if the instruction manual has not been read and understood. Please have this instruction manual available whenever you call for technical support.

For further technical support please contact your distributor. Do not call the Fike Safety Technology support department unless your distributor has first given their advice and attempted to rectify the issue.

EMC



This equipment when installed is subject to the EMC Directive 2014/30/EU. It is also subject to UK Statutory Instrument 2006 No. 3418.

To maintain EMC compliance this system must be installed as defined within this manual. Any deviation from this renders the installer liable for any EMC problems that may occur either to the equipment or to any other equipment affected by the installation.

The CIE-A-200 System

The CIE-A-200 system is an addressable intelligent detector system, with many advantages over traditional addressable analogue sensor systems. In order to understand the benefits, let us look more closely at the terms **Fire Detector** and **Fire Sensor**. These terms are often used interchangeably but actually have quite different meanings. A fire detector is the device (component as defined in EN54) which automatically detects a fire. In the majority of addressable fire detection systems, the fire devices are in fact fire sensors which only transfer data relating to smoke and heat levels to the control panel, and the fire decision is made by the panel.

Nearly all current addressable systems are **Addressable Analogue Detector Systems** where the control panel continually scans the fire sensors, processes the returned data, and makes decisions about fires and faults.

The CIE-A-200 system is defined as an **Addressable Intelligent Detector System** or an **Addressable Fire Detection and Alarm System with Independent Distributed Intelligence**. Distributed intelligence signifies that the signal processing is spread throughout the system, in order that the decisions about fires and faults are taken within the detector itself. The detector is capable of being remotely programmed for different modes of detection.

Thus the CIE-A-200 system is an analogue addressable system, but with the processing power distributed across the entire system. This dramatically reduces the complexity of the control panel and the data traffic, and improves the efficiency of the system.

The system addressing is carried out automatically upon initialisation from the control panel, and does not need to be programmed manually at each device.

Each device has a built in isolator. When the loop is initialising the panel addresses each device on the loop starting with the first device connected to Loop End 1, when the first device has been addressed it will close its isolator and allow the second device to be addressed. This process will carry on and finish with the last device connected to Loop End 2. When the last device is addressed and closes its isolator power is applied to Loop End 2, the panel detects this and reports Loop Complete.

The panel will then check for addressable spurs on each device. Addressable spurs are no longer used; this operation is only to allow for backward compatibility where this panel may be used to replace an old system which is using addressable spurs.

Advantages of Addressable Systems

The nature of a microprocessor control system with individually identified devices means that the precise location of fires and faults may be indicated, more complex actions may be implemented, system flexibility is improved and installation and cabling costs are reduced.

In the CIE-A-200 system, very efficient communications mean that very low quiescent power consumption maximises the standby capacity, high power transfer capabilities allow more sounders to be connected to the loop, and a very fast response to events is achieved as the control panel does not have to poll every device for status data.

Control Panel

Mounting the Control Panel

First, identify the proposed location for the control panel. Ensure that the control panel will be easily accessible, and that account is taken of any subsequent work that may affect access. It should be located at the most likely point of access for the fire services.

The control panel should be mounted on a flat, vertical wall at a height where the indicators may be seen without difficulty.

Do not locate the control panel at high level where stepladders or other access equipment may be required, in spaces with restricted access, or in a position that may require access panels to be removed.

Do not locate the control panel where extremes of temperature or humidity may occur, or where there is any possibility of condensation or water ingress.

Like all electronic equipment, the control panel may be affected by extreme environmental conditions. The position selected for its installation should therefore be clean and dry, not subjected to high levels of vibration or shock and at least 2 metres away from any pager or radio transmitting equipment. Ambient temperatures should be within the range given within the Technical Data section, i.e. not directly over a radiator or heater or in direct sunlight.

In common with all microprocessor-controlled panels, the control panel may operate erratically or may be damaged if subjected to lightning induced transients. Proper earth/ground connections will greatly reduce susceptibility to this problem.

The General Assembly with front door removed

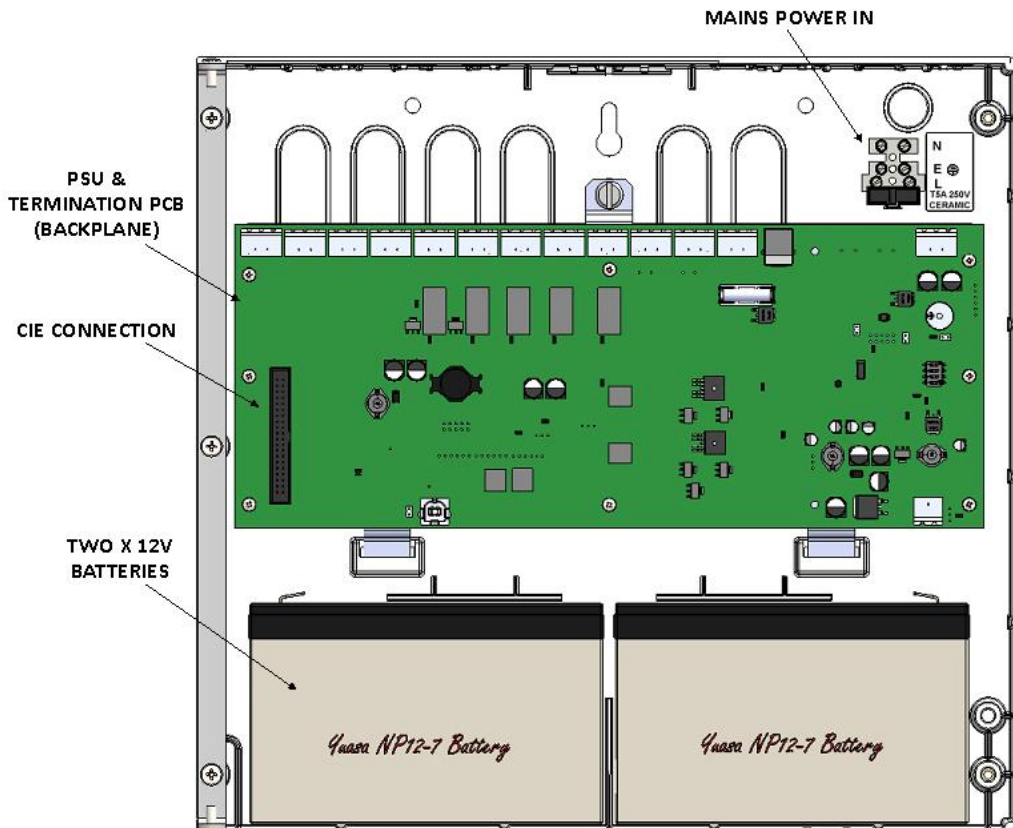

Control Panel Disassembly

The backboard assembly is attached to the panel back box by two brackets on the bottom of the assembly, the two brackets hook into the back box. There is a single captive knurled screw in the centre at the top of the assembly which holds it in.

Disconnect the ribbon cable that goes to the CIE board, unplug all cables and disconnect the earth strap. Unscrew the single knurled screw in the centre at the top of the assembly, tip the assembly forward and lift it out from the two lower brackets.

If it is necessary to remove the door that houses the CIE in order to replace the CIE, the door must be opened to its full extent and the ribbon cable unplugged from the main backplane.

Then the two hinge screws must be removed. The door can then be completely removed.

Physical Dimensions

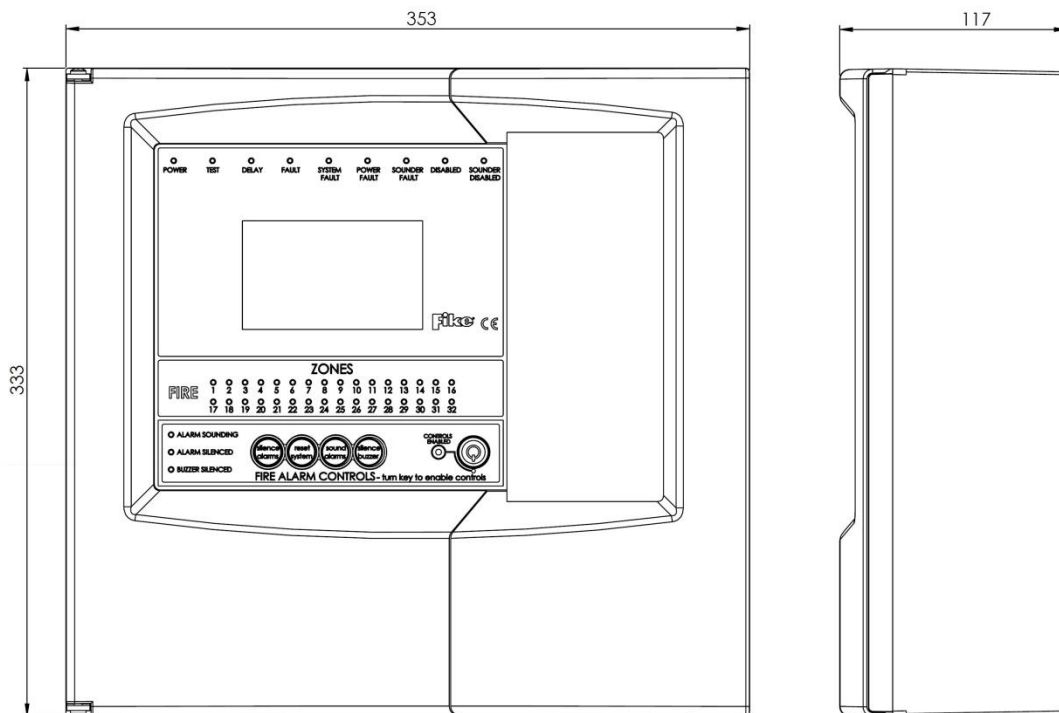

Cabinet Installation

Surface Mounting

The three mounting holes should be used to secure the cabinet to a solid wall using suitable screws of at least 50mm in length. Ensure that a minimum gap of 50mm is left between the sides of the back box and any wall or projection (such as another box).

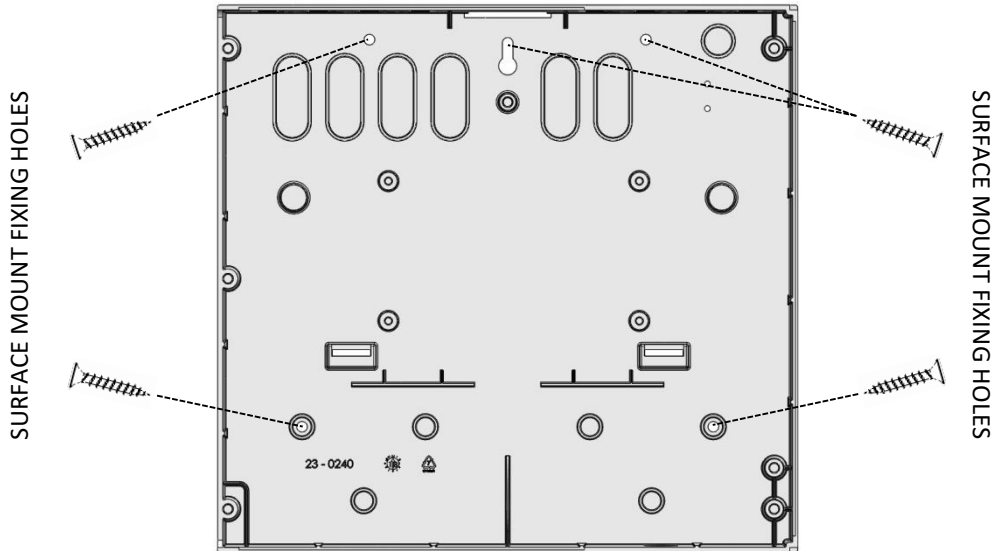

Flush Mounting

A cradle, part number **23-0239** (sold separately) must be used when flush mounting the panel. The flush mounting hole size is 354mm wide x 334mm high.

When flush mounted the panel will sit at a depth of 83mm into cavity and have 36mm protruding from surface.

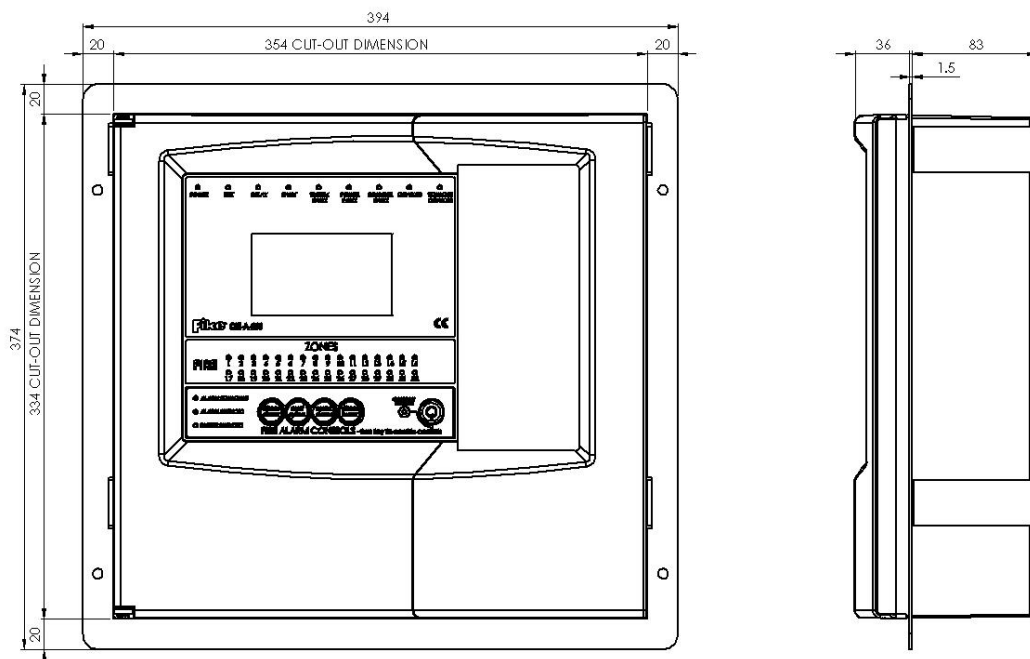

Cable Entry

The cable entry locations are provided by two rows of knockouts at the top, six on the back and one on the bottom.

The bottom knockout should be used if the 12Ah battery box is used.

The rear bottom half of the panel must be kept clear for mounting the 7Ah internal batteries.

It is recommended that fire rated cable glands are used to ensure that the characteristics of the enclosure can be maintained adequately.

Mounting Data

Panel Dimensions:	Width x Height Depth	353mm x 333mm 117mm
Flush Mount Hole Size:	Width x Height (with cradle) Depth	354mm x 334mm 83mm

Control Panel Assembly

The backboard assembly is attached to the panel back box by two brackets on the bottom of the assembly, the two brackets hook into the back box. There is a single captive knurled screw in the centre at the top of the assembly which holds it in.

To fit the backboard assembly, tip the assembly forward and hook the two lower brackets into the back box then bring the assembly upright and then secure it with the knurled screw.

To refit the front door which houses the panel controls, line up the top & bottom threaded holes in the left hand side of the door with the hinge bracket on the back box and fit the two hinge screws. Connect the ribbon cable to the back board and CIE.

Addressable Circuit Wiring

Topology & Cabling

All system wiring should be installed to comply with the current BS 5839: Pt 1 and BS 7671 (wiring regulations) and any other standards relevant to the area or type of installation. A cable complying with the current BS 5839: Pt 1: Category 1 (cables required to operate for prolonged periods during fire conditions) is required. This must be a 2-core 1.5mm² screened fire resistant cable (ie.FP200, Firetuff, Firecell, Lifeline or equivalent).

Cable Specification

Max Capacitance Core to Screen	180pF / m
Max Capacitance Core to Core.....	100pF / m
Max Inductance.....	1.0mH / km
Max Resistance Two Core Screened 1.5mm ²	12.1Ω / km
Fire Proof	BS5839: Pt1: Category 1
Example	FP200, Firetuff, Firecell

The addressable circuit must be installed as a loop with a maximum length of up to 2 km.

Spur circuits are NOT permitted with this system.

In order to protect against possible data corruption, it is important ensure the following points are adhered to:

1. The addressable circuit cable **screen must be connected to the loop SCRN terminal at the control panel**. Both ends must be connected using the terminals provided.
2. The addressable circuit cable screen must not be connected to earth/ground at any point other than the control panel (at the SCRN terminal provided, not at any earthing point). **Do not connect the screen to a device back box (flush)**.
3. The addressable circuit cable **screen continuity must be maintained** at every point of the loop, using the terminals provided or a suitable connection block.
4. **Do not use a 4-core cable** as a loop **feed & return** due to the possibility of data corruption. It is essential that two 2-core cables are used if this is required.
5. Excess cable lengths **must not be coiled** as coiling will increase the inductance and cause communication problems.
6. Fire alarm addressable circuit cabling must be separated from other building system cables by at least 300mm and not run within 500mm of any mains power cables.
7. Avoid running fire alarm addressable circuit cables in parallel with mains power or any other building system cables. Where a cross-over between fire alarm addressable circuit cables and mains power or other building system cables is unavoidable, the cables should be arranged to cross at right angles with as much separation as possible.
8. Fire alarm cabling should not be run in any cable management system such as trunking, conduit or on cable trays that are being used by mains power or other building system cables.

Loop Loading

In order to allow a method of calculating the maximum loop loading that the system will support, each device has a rating assigned in Device Loading Units (DLUs). This relates to the load presented in alarm. A maximum of 450 DLUs are permissible on each loop (subject also to a maximum of 200 addressable devices, whichever limit is reached first).

The DLUs of the current models of devices as at October 2018 are as follows:

PRODUCT DESCRIPTION			DLU RATING			
Type	Product Code	Subtype	SP0 - Off	Low	Medium	High
MP	203 0003	Multipoint Mk3	1	-	-	-
	205 0003	ASD Mk3	1	-	-	-
MPS	203 0001	Multipoint with Sounder Mk3	1	1.5	4.5	6
	205 0001	ASD with Sounder Mk3	1	1.5	4.5	6
	205 0012	ASD with Sounder/Strobe Mk3	4.5	5	8	10
MCP	403 0006	Manual Call Point Mk3	3	-	-	-
	403 0007					
SOUNDER	313 0001	Soundpoint Mk3	1.5	2	4	5.5
	313 0002					
	323 0001	Hipoint Mk3	1.5	2	4	5.5
	303 0012	Flashpoint	1.5	4.5	6.5	8
	303 0022					
	326 0021	Sounder/Strobe	9	9.5	11.5	13
326 0023						
326 0001	Sounder	1.5	2	4	5.5	
326 0003						
326 0015	Strobe	9	-	-	-	
I/O	803 0006	Loop I/O Module Mk2	10.5	-	-	-
CZM	803 0010	Conventional Zone Module (Loop Powered)	23.5	-	-	-
	803 0010	Conventional Zone Module (Ext PSU)	3.5	-	-	-
ANCILLARY	803 0003	Multipoint I/O Module (in Relay Base)	3	-	-	-
	803 0005					
	600 0092	Remote Indicator	0.5	-	-	-

The CIE-A-200 OSP programming software v1.00 automatically keeps control of the quantities and DLU ratings of devices on the loop and will warn the engineer if the limit is reached. It will not allow a system to be programmed to exceed the maximum DLU rating.

It can detect the type of the device and, in the case of devices manufactured from March 2010, the subtype from the above list as well. For devices manufactured prior to this date, the CIE-A-200 OSP will attempt to detect the subtype and use the appropriate DLUs. The engineer can override the automatically detected subtype if required i.e. if the OSP cannot correctly identify an older device, the engineer can tell the system that the device is a different subtype to the one OSP has selected (e.g. a Soundpoint instead of Flashpoint) within the same main type. The OSP can also work out the standby battery calculations.

Note: An Excel spreadsheet (document no. 26-1765) is also available to automatically work out both standby battery calculations and loop loading calculations based on the quantities entered. This includes ratings for legacy devices as the above current models.

General System Schematic

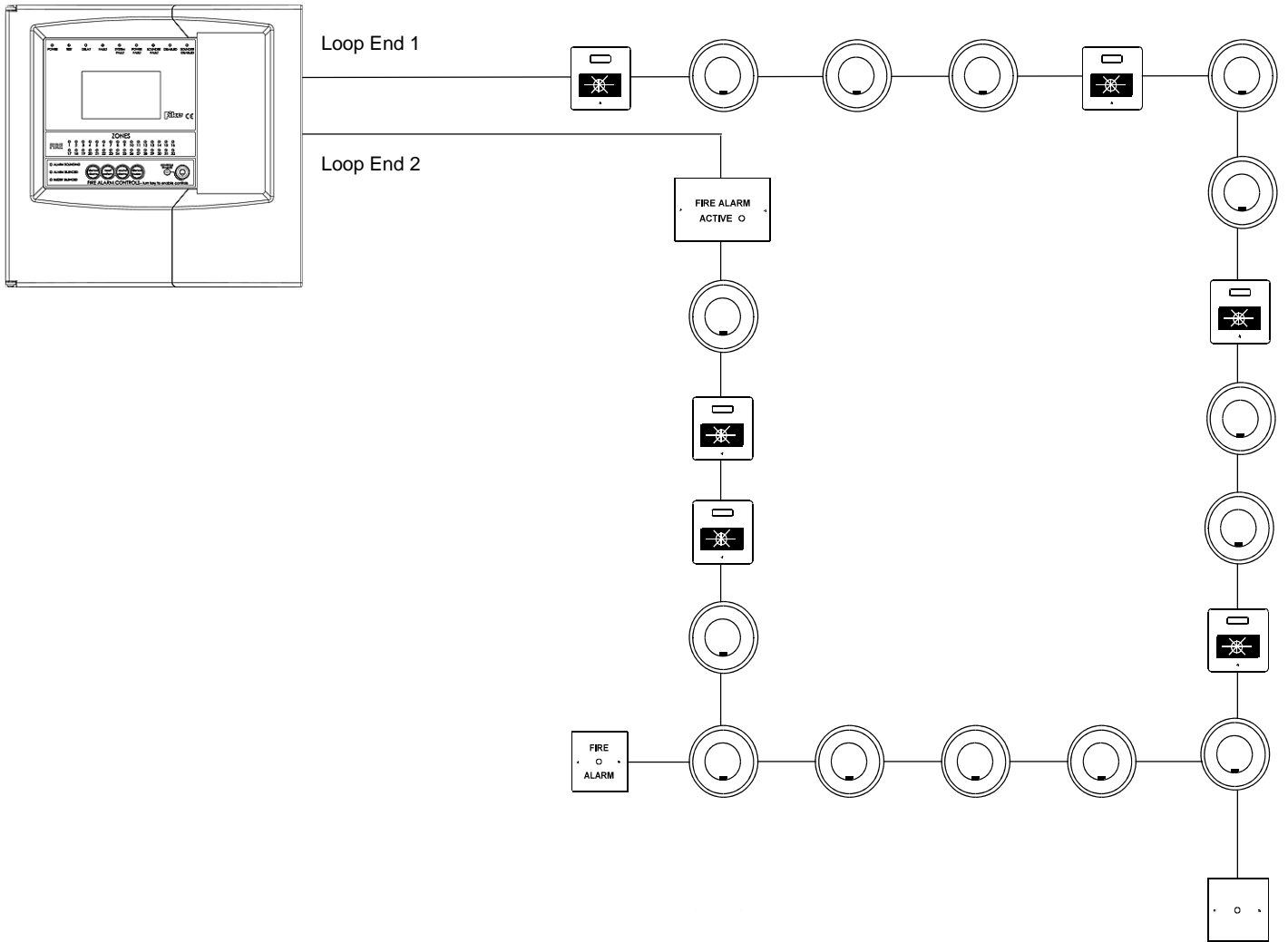

Sita Multipoint / ASD



Sita MP I/O



Sita MCP



Remote Indicator



Sita Loop I/O Module

Control Panel Main PCB - Control & Indicating Equipment (CIE)

The Control Panel PCB is located on the inside of the front inner door.

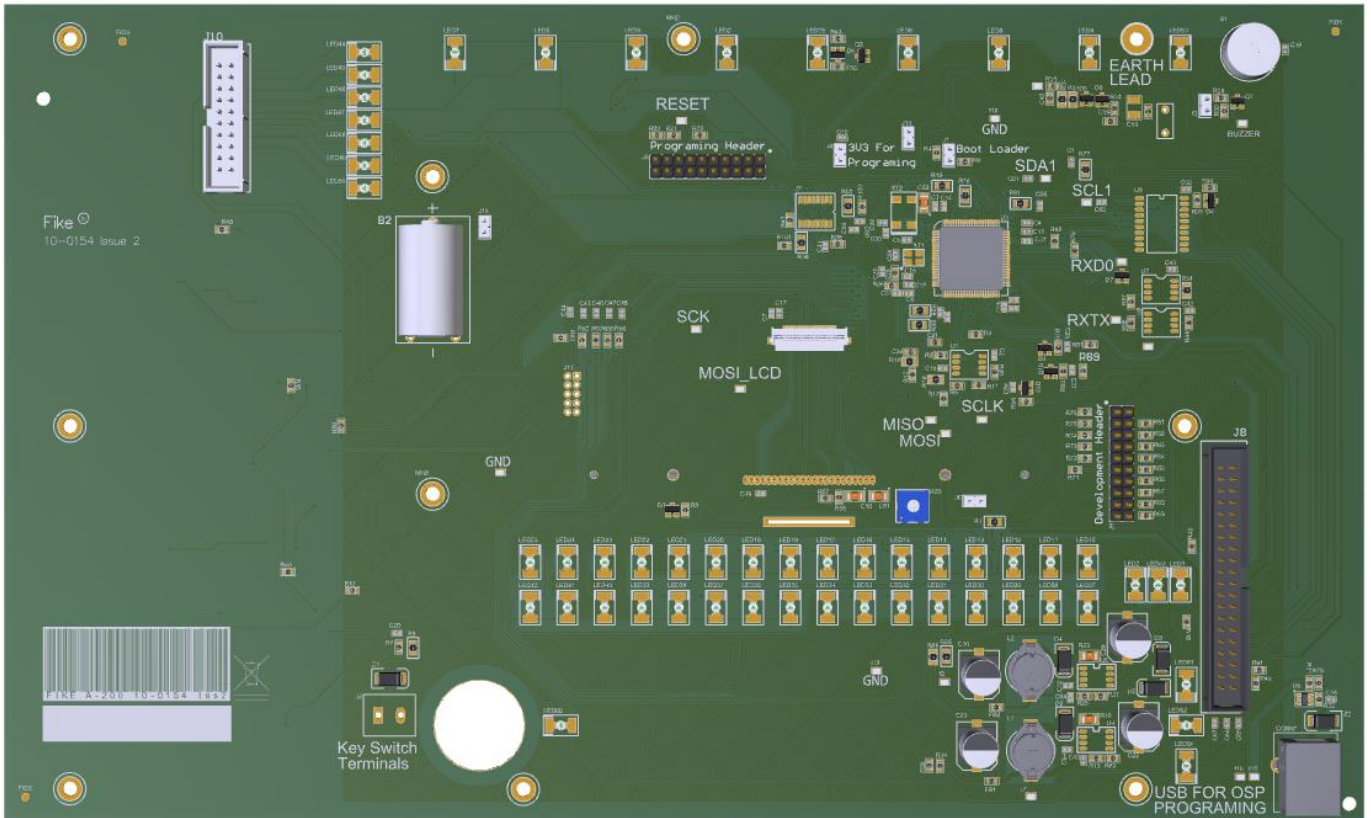

USB for OSP Programming

The USB for OSP Programming is used to connect a computer to the CIE. CIE-A-200 OSP and a USB-A to USB-B lead is required in order to program the CIE via a computer. Please note that an Earth Fault may be present when a computer is connected. This fault will clear when the USB cable is removed.

LCD Contrast

The LCD contrast may be adjusted by rotating the screw on the variable resistor located near the centre of the main PCB. This is set at the factory but can be adjusted if required.

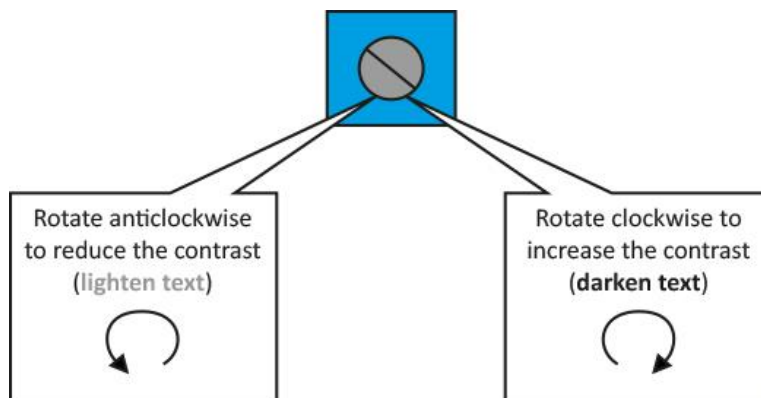

Control Panel Backplane & Terminals

The Termination PCB (also known as the backplane) is located at the rear of the main control panel back box.

Panel Backplane Layout

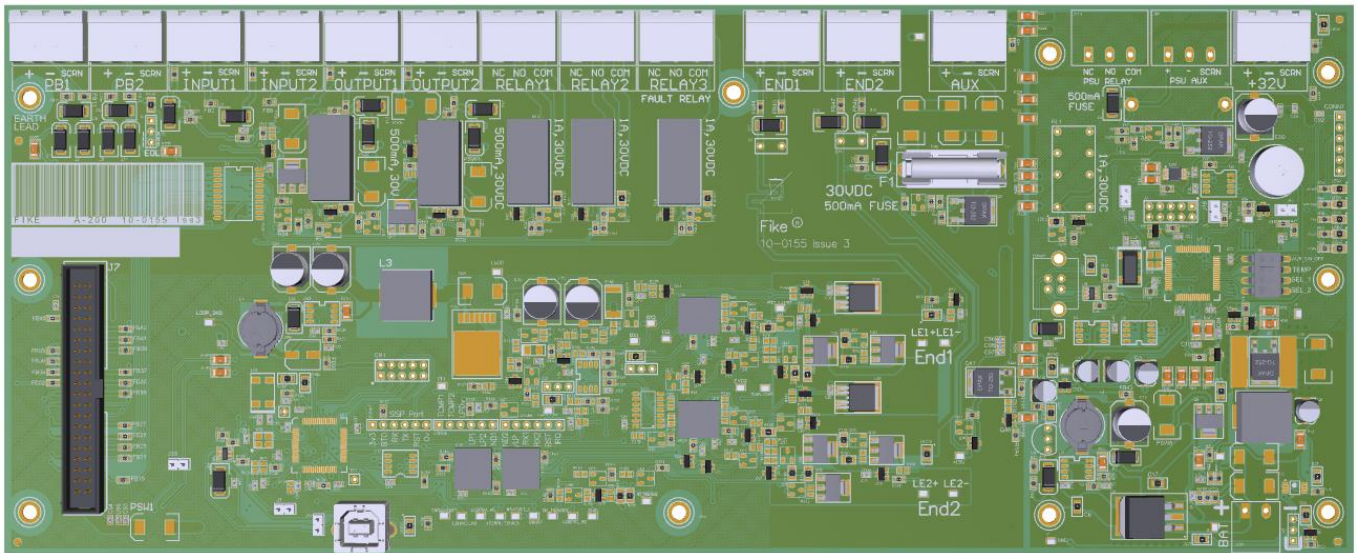

The connections on the top from left to right:

PB_1	Peripheral bus 1 for repeater connection
PB_2	Not yet implemented
MON_IN_1	Monitored input 1
MON_IN_2	Monitored input 2
MON_OUT_1	Monitored output 1
MON_OUT_2	Monitored output 2
RELAY_1	Default setting - Fire output 1
RELAY_2	Default setting - Fire output 2
FAULT_RELAY	Default setting - Fault output general panel fault notification
END_1	Loop end 1
END_2	Loop end 2
AUX_OUT	Auxiliary power output, 30V DC 450mA
32V_INPUT	Main power input from PSU

The connections on the bottom from left to right:

ENGR_LOOP_USB	Factory use only
BATT	Battery connection

Peripheral Bus (PB_1 & PB_2)

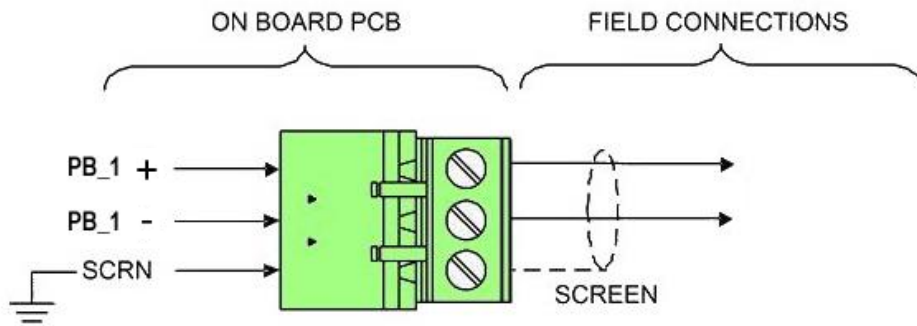

Communications between the panel and repeater is via a multi-drop RS-485 Peripheral Bus. 2-core 1.5mm² screened fire resistant cable (i.e. FP200, Firetuff, Firecell) cable should be used for communications to the repeater.

The maximum total cable length from the control panel to a repeater is 500 metres. Up to 8 repeaters can be used but they must all be within the maximum 500 metres cable length and are wired + to +, - to -, the screen must be connected to the control panel at one end only using the terminals provided. Terminate the unused end in a connector block as shown below and so on up to the maximum of 8 repeaters.

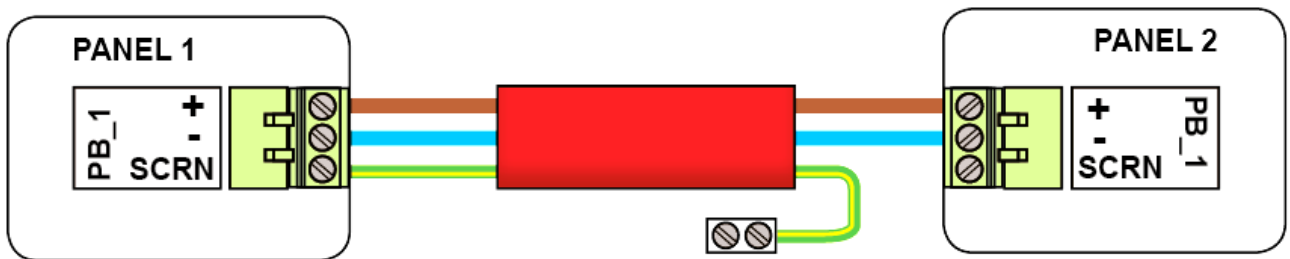

The peripheral bus must be run from the panel to the first repeater then the second repeater and so on; the peripheral bus must not be spurred from one point.

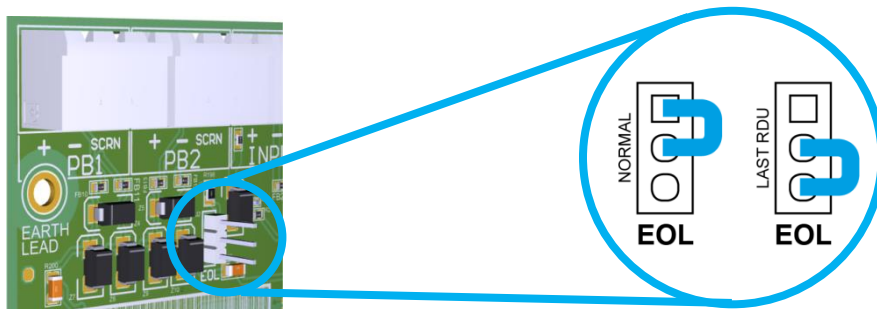

The jumpers are fitted to impedance match the cable with the driver ICs & prevent signal reflections down the cable. The jumpers **must** be changed on the **CIE** and last **RDU**.

Terminal	Description
+	Connects to the + connection on the repeaters
-	Connects to the - connection on the repeaters
SCRN	Field cable screen connection

PB 2 is not currently used and is for future development.

Monitored Inputs (MON_IN_1 & 2)

Monitored input set as a normally open input

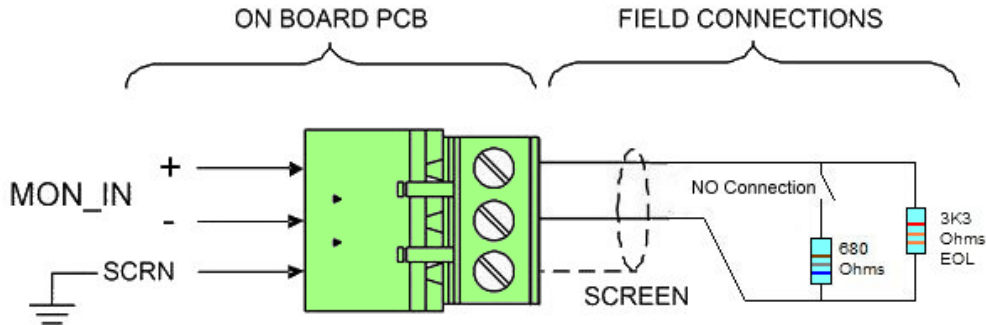

Maximum Voltage at contacts, 3.3 Volts. Maximum current 10mA.

Monitored Inputs 1 & 2 will monitor for open and short circuit faults using a 3k3 EOL resistor. To activate the input, connect a 680R or 470R 'triggering' resistor across + & -.

Terminal	Description
+	Monitored Input positive connection
-	Monitored Input 0V connection
SCRN	Field cable screen connection

Monitored Outputs (MON_OUT_1 & 2)

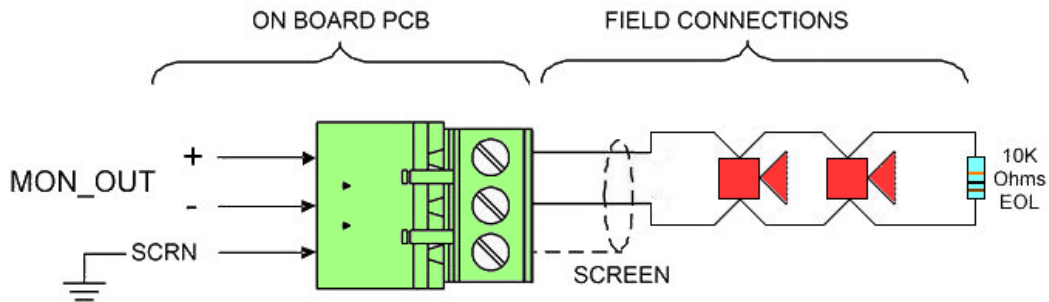

Outputs 1 and 2 are monitored circuits which are monitored for open and short circuit faults with a 10k EOL resistor. Sounders used on monitored outputs must be 24v conventional type sounders.

Any relays must be dioded for polarisation and suppression. Diodes are usually incorporated in fire relays but if they are not incorporated use diodes part number 1N4002.

The diagram below shows the diode arrangement required if non-dioded relays are used on monitored outputs.

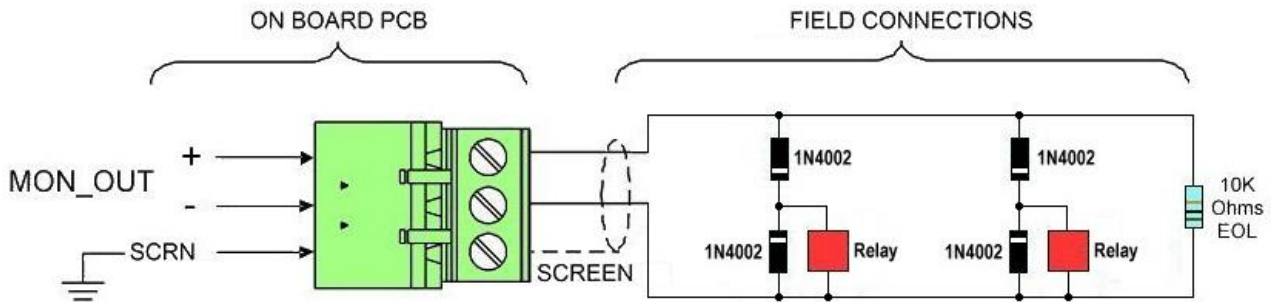

The default setting for monitored output 1 is a **Monitored Sounder Output** and the default setting for monitored output 2 is a **Common Fire Output**.

The maximum continuous output current for each output is **500mA**.

- Monitored Outputs can be set as follows:
- Not Configured
 - Fire Output
 - Sounder Output
 - Sounder Output Cadence
 - Common Fault

Terminal	Description
+	Monitored Output positive connection
-	Monitored Output 0V connection
SCRN	Field cable screen connection

Relay Outputs 1, 2 & Fault Relay Volt Free Contacts: NO, NC, COM

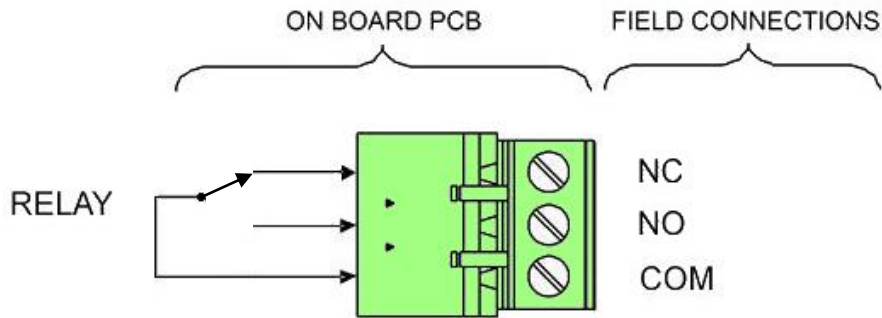

Relays 1, 2 and the Fault Relay are derived from single pole change over 'volt-free' relay contacts which are not fault monitored. The relay contacts are rated at 1A @ 30VDC. All inductive loads should be diode protected to prevent back EMF. However, if this is not done, the load should be limited to 200mA to reduce the likelihood of back EMF causing damage to the relay contacts.

The default setting for Relay Outputs 1 & 2 is as **Common Fire** outputs where the relay is energised in the fire condition.

- Relays 1 & 2 can be set as follows:
- Not Configured
 - Fire Output (Common)
 - Fire Output (Zonal)
 - Common Fault

The Fault Relay cannot be configured and will always operate as a **Common Fault** output where the relay is de-energised in the fault condition.

In order to meet the requirements of EN54-2, one relay must be left as a fire output.

Terminal	Description
NO	Normally open contact
NC	Normally closed contact
COM	Common contact

Addressable Loop: END1+, END1-, SCRN, END2+, END2-, SCRN

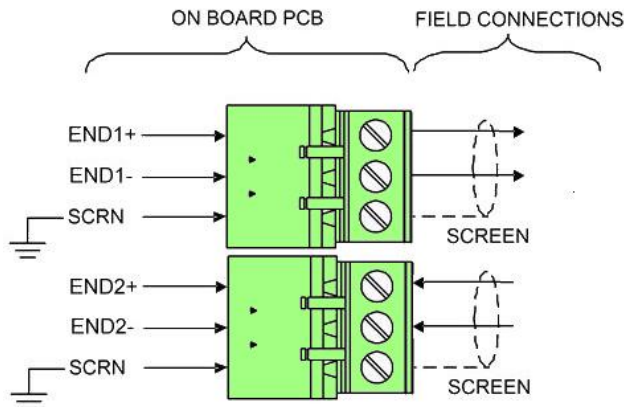

The Loop addressable circuit must be connected to its End 1 and End 2 terminals.

Once initialised the loop is powered from both ends.

Communications run from Loop End 1 but, in the event of a continuity fault, (O/C or S/C) communications will be sent from both ends of the loop so for a single loop fault, no devices will be lost.

It is important that the cable screen is only connected to the control panel at the SCRN terminal provided, not at any other earthing point, and that the screen continuity is maintained at all times.

4-core cable must not be used as a loop 'feed & return' due to the possibility of data corruption.

Terminal	Description
LOOP END1+	Circuit End 1 positive connection: +VE OUT
LOOP END1-	Circuit End 1 0V connection : 0V OUT
SCRN	Field cable screen connection: SCRN OUT
LOOP END2+	Circuit End 2 positive connection: +VE IN
LOOP END2-	Circuit End 2 0V connection : 0V IN
SCRN	Field cable screen connection: SCRN IN

Auxiliary Power: 30V, 0V, SCRN

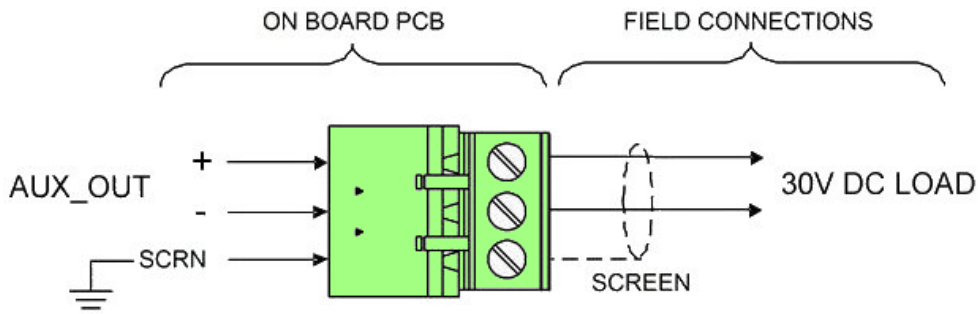

An auxiliary nominal 24V DC power supply is available to power ancillary devices requiring up to 30V DC. The maximum output current is **450mA**. The Auxiliary Power output is protected by **T500mA** fuse F1.

The Auxiliary can also be set to resettable to allow ancillary devices connected to be reset. Resettable Auxiliary will switch off the Auxiliary power for 5 seconds before turning back on.

It is suggested that additional external power supply units be installed to provide power for additional loads. Additional external power supply units with their own battery backups are recommended when the panel is required to run for extended battery standby times.

Note: The auxiliary power supply outputs will be approximately 30 – 31V DC when the panel is running from a mains supply and between 20 and 26V DC when running from the batteries in a mains failure condition.

Please ensure that the equipment to be powered from this output is capable of operating from between 19V and 32V DC.

Terminal	Description
+	Aux power positive 24V connection (20V to 31V DC Unregulated)
-	Aux Power 0V connection
SCRN	Field cable screen connection

32V Power Input

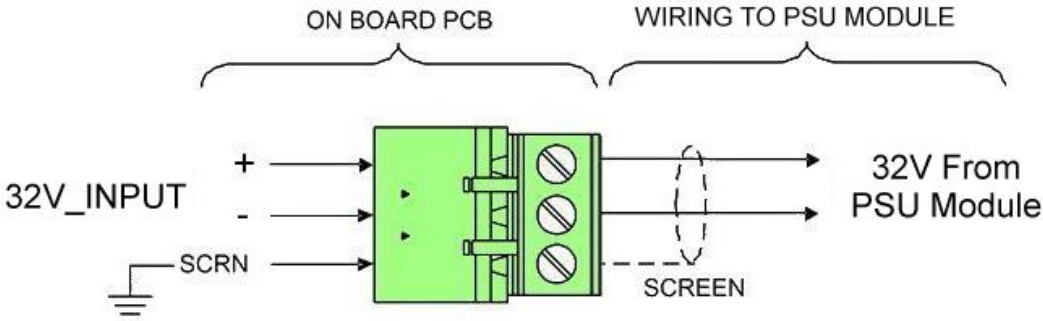

The panel requires a DC supply voltage of 27.5V – 33.5V which is supplied by the internal 150W switch mode PSU module.

This provides all the power and battery charging requirements.

CIE door USB Port: USB for OSP Programming

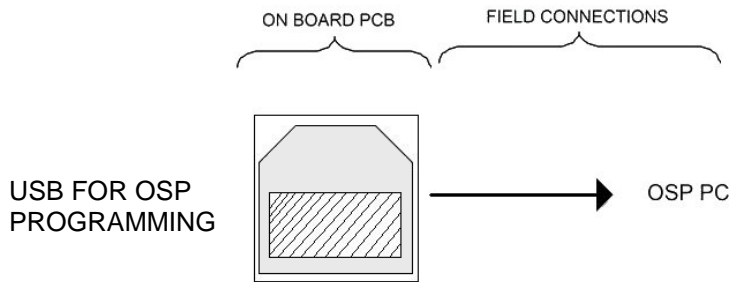

The CIE-A-200 control panel may be programmed using the CIE-A-200 OSP programming software with a USB lead to link the User USB port to a computer. This allows the site specific data to be customised as required.

NOTE: It is imperative that the correct version of OSP is used to match your version of CIE-A-200 control panel. The use of an incompatible version may result in incorrect operation of the control panel.

This port is also used for connection to a computer running the panel diagnostic software.

Back Board ENG LOOP USB Port

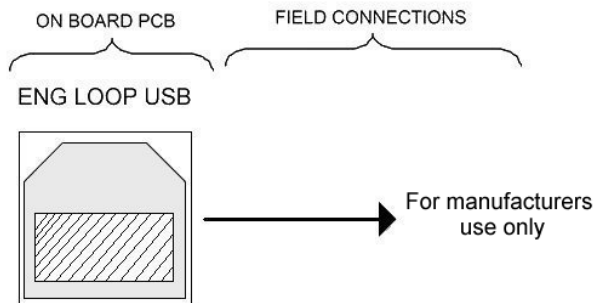

The Engineering Loop USB port is for manufacturers use only.

Mains Supply & Batteries

The Fire Alarm Panel 230V AC supply requires fixed wiring between 1 mm² and 2.5 mm², with a 3 amp fused un-switched spur with local isolation. The mains supply should be dedicated to the Fire Alarm Panel and should be clearly labelled 'FIRE ALARM: DO NOT SWITCH OFF' at all isolation points.

Back Box Mains connection

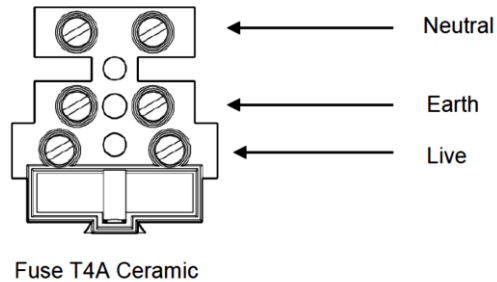

If the mains fails and the panel is running on the battery supply the panel will shut down when the battery voltage reaches the lowest voltage. This is approximately 21V and is an EN54 requirement to prevent the batteries being deep discharged.

The panel will not however shut down if the batteries reach the Lowest Voltage while the panel is running on the mains supply.

The standby time will vary depending on the system loading. The CIE-A-200 panel requires 2 x 12V 7Ah or to increase battery standby times 2 x 12V 12Ah sealed lead acid batteries.

The 7Ah batteries are housed in the bottom part of the back box. The 12Ah batteries are housed in a separate battery box.

The batteries should be connected in series using the fused connection leads supplied.

We recommend the use of Yuasa NP7-12 or other equivalent approved types.

To increase battery standby times, use Yuasa NP12-12 or other equivalent approved types.

Do not use any other capacity batteries on this system.

Using different capacity or type of batteries could also invalidate any warranty.

The panel can only use either 2 x 7Ah or 2 x 12Ah batteries it cannot use both sizes at once.

The 2 x 12V 12Ah sealed lead acid batteries are housed in a separately provided battery box, part number **550-0020** (sold separately). This should be mounted below the main panel and use a conduit coupler to link the battery box wiring to the main panel back box.

The correct battery charger settings must be selected for the size of battery used, this is done using DIL switch S1 – 1 and S1 – 2.

Battery Capacity	Switch S1 - 1	Switch S1 - 2
7Ah	ON	ON
12Ah	OFF	OFF

If these settings are incorrect for the batteries being used it will either cause the batteries to be over charged or under charged. Incorrect settings could cause damage to the batteries.

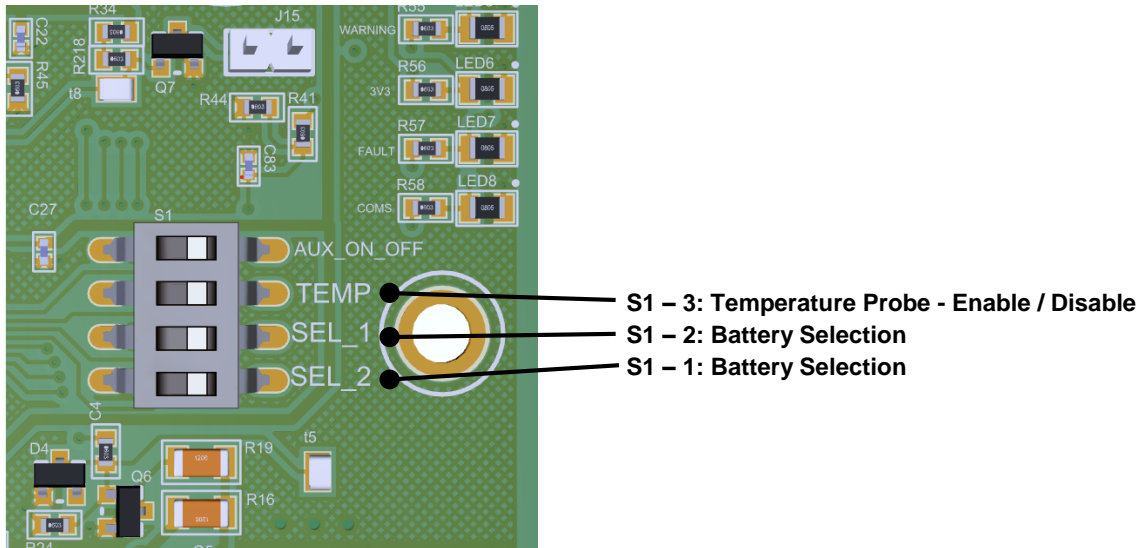

Note that batteries are electrically live at all times and great care should be taken to ensure that the terminals are never presented with a short circuit. Care should be taken at all times, especially during transit, installation and normal use.

Use caution as there is a risk of explosion if the batteries are replaced by an incorrect type.

Batteries no longer required should be disposed of in a safe and environmentally friendly manner by the battery manufacturer or a suitable recycling service. They should never be incinerated or placed in normal rubbish collection facilities. Dispose of used batteries according to the manufacturer's instructions.

Fuses 1 and In-Line Battery Fuse

Fuse 1 is located on the backplane PCB, the In-Line battery fuse is located in the battery feed positive line.

Panel Backplane		
Label	Description	Fuse
F1	Auxiliary Power	T500 mA
IN-LINE	Battery	F3.15A

Battery Temperature Probe

There is a temperature sensor on the PCB; there is also provision for an external battery temperature probe part number **17-0162**. This is on a fly lead which plugs into the PCB; it can be placed close to the battery for a more accurate battery temperature reading. If a battery temperature probe is used it must be enabled using DIL switch S1 – 3.

- Switch DIL S1 – 3 OFF to enable the external battery temperature probe and ON to enable the internal battery temperature sensor.

If the battery temperature probe is not used the battery temperature reading will use the on board PCB temperature sensor.

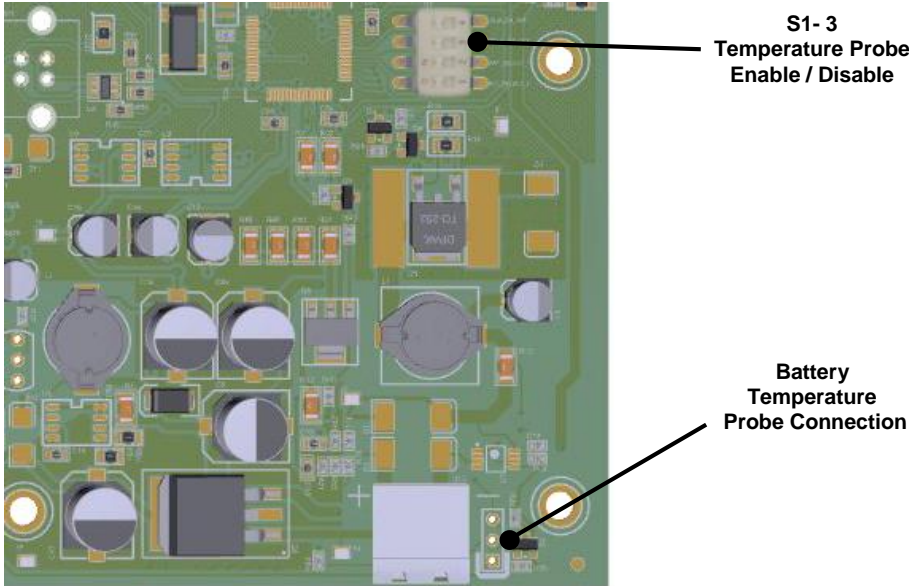

Battery Connections

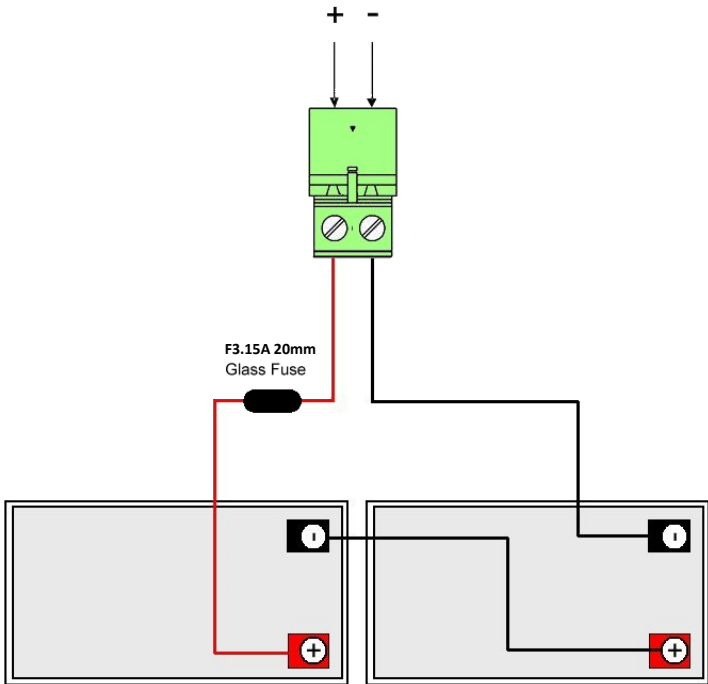

General Operation of Control Panel

Control Panel Front

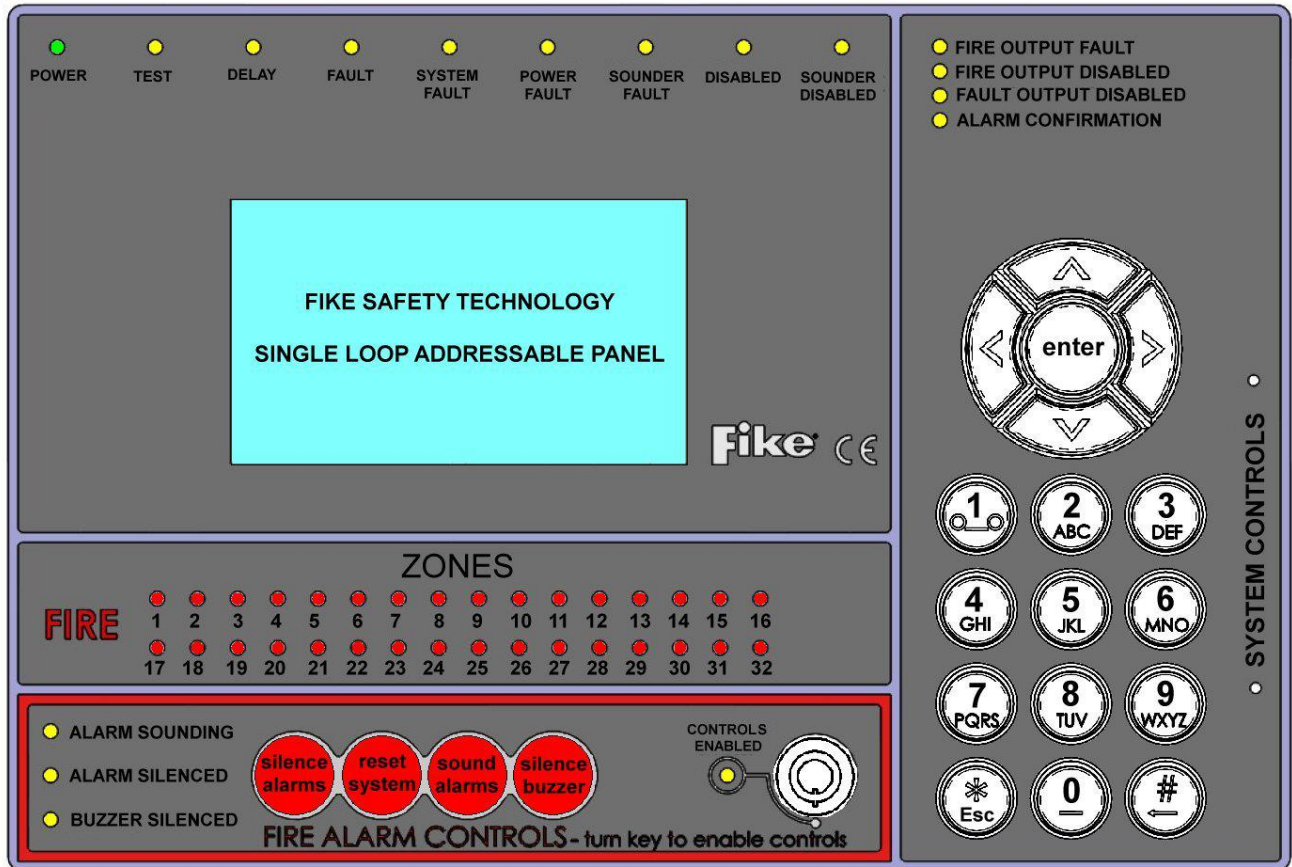

LED Indication

The operation of the LED indications on the front of the control panel is described below.

	Description	Colour	State	Reason
1.	POWER	Green	Continuous	This indicates that power is being supplied to the control panel from either the 230V AC mains supply, or the standby batteries.
2.	TEST	Yellow	Continuous	This indicates that a test routine is in place. End all tests to clear.
3.	DELAY	Yellow	Continuous	An action has been started which utilises a programmed delay.
4.	FAULT	Yellow	Continuous	The control panel is in the fault state. Other indicators will show the origin.
5.	SYSTEM FAULT	Yellow	Continuous	The system Fault LED indicates the presence of a processor or a checksum error. Power the system down to clear, reprogram all settings and test the system.
6.	POWER FAULT	Yellow	Continuous	The mains supply or standby battery supply has failed (check the fuses, battery and the 230V AC supply).
7.	SOUNDER FAULT	Yellow	Continuous	A fault condition is present on a monitored sounder circuit or on the addressable device loop sounders.
8.	DISABLED	Yellow	Continuous	This indicates that a disablement action is in place. Enable all devices / actions to clear.
9.	SOUNDER DISABLED	Yellow	Continuous	This indicates that a sounder disablement action is in place. Enable all devices / actions to clear.
10.	FIRE OUTPUT FAULT	Yellow	Continuous	A fault condition is present on a monitored Fire Output circuit or on the addressable device loop outputs.
11.	FIRE OUTPUT DISABLED	Yellow	Continuous	This indicates that a Fire Output disablement action is in place. Enable all Fire Outputs to clear.
12.	FAULT OUTPUT DISABLED	Yellow	Continuous	This indicates that a Fault Output disablement action is in place. Enable all fault outputs to clear.
13.	ALARM CONFIRMATION	Yellow	Continuous	A smoke detector is in the alarm confirmation state, awaiting confirmation or reset.
14.	FIRE	Red	Continuous	The control panel is in the fire state. Other indicators will show the origin.
15.	ZONE 1-32	Red	Continuous	The control panel is in the fire state. The zone LED will illuminate to indicate the zone where the fire as occurred. More zone LEDs may be illuminated if fires have been detected in more than one zone.

16.	ALARM SOUNDING	Yellow	Continuous	The alarm sounders have been activated from the Sound Alarms button on the panel.
17.	ALARM SILENCED	Yellow	Continuous	The alarms have been silenced whilst operating and will stay silenced until another fire or relevant action occurs.
18.	BUZZER SILENCED	Yellow	Continuous	The control panel buzzer has been silenced whilst operating and will stay silenced until another fault or relevant action occurs.

Fire Alarm Controls

The main Fire Alarm Controls may be enabled by turning the key switch to the controls enabled position, or by entering a valid Access code (see page 32 for access codes).



System Controls

User

- 1. View Current Events**
- 2. Test Controls & Display

Supervisor

- 1. View Current Events**
- 2. Test Modes
- 3. View Logs
- 4. Delay On/Off
- 5. Enable/Disable
- 6. Time & Date Settings
- 7. Find Device
- 8. Diagnostics
- 9. Access Levels

Engineer

- 1. View Current Events**
- 2. Test Modes
- 3. View Logs
- 4. Delay On/Off
- 5. Enable/Disable
- 6. Time & Date Settings
- 7. Find Device
- 8. Diagnostics
- 9. Loop Controls
- 10. View Edit Attributes
- 11. Panel I/O
- 12. Panel Details
- 13. Peripheral Bus Settings
- 14. Auto Zoning
- 15. Alarm Resound



A context-driven highlighted-selection menu system is used to navigate the menu system, automatically prompting you with the relevant options for your Access Level and system status.

The menus may be navigated in one of two ways as required:

1. Use the **UP / DOWN** keys to move the highlighted selection and press **ENTER** to select the chosen one.
2. Enter the desired option number and press **ENTER** to select it.

Press the **Esc** key to exit to the previous menu.

Access Levels and Codes

The menu system is divided into four access levels in order to restrict access to those who require it. For simple indication the status of the **Controls Enabled** light will show the level selected as follows:

Access Level	Description	Shift LED	Key Operation	Default Code	Page
0 – NORM	Normal	OFF	NO	N/A	32
1 – USER	User	ON	YES	8737	33
2 – SUPR	Supervisor	SLOW FLASH	NO	7877	34
3 – ENGR	Engineer	FAST FLASH	NO	3647	40

Access to the menu system requires either the operation of the **enable controls key** for access to Access Level 1 (User), or the correct entry of the relevant code for access to all other levels, in order to protect against unauthorised access to the system. The codes may be changed using the CIE-A-200 OSP software or from the Engineers menu on the panel.

A valid access level code must be entered in order access any of the menus.

Access Level 0 (Normal): Controls Enabled LED off

At Access Level 1 (Normal), the main **Fire Alarm Controls** are disabled and the Controls Enabled LED is switched off.

A valid access level code must be entered or the key switch must be used in order access any of the menus.

Delay Override

To comply with EN54-2 Clause 7.11.1d, a manual call point (MCP) should be located next to the CIE to override the delayed output by a manual operation.

Access Level 1 (User - 8737): Controls Enabled LED on

At Access Level 1 (User), the main **Fire Alarm Controls** are enabled, and the following **System Controls** are accessible:

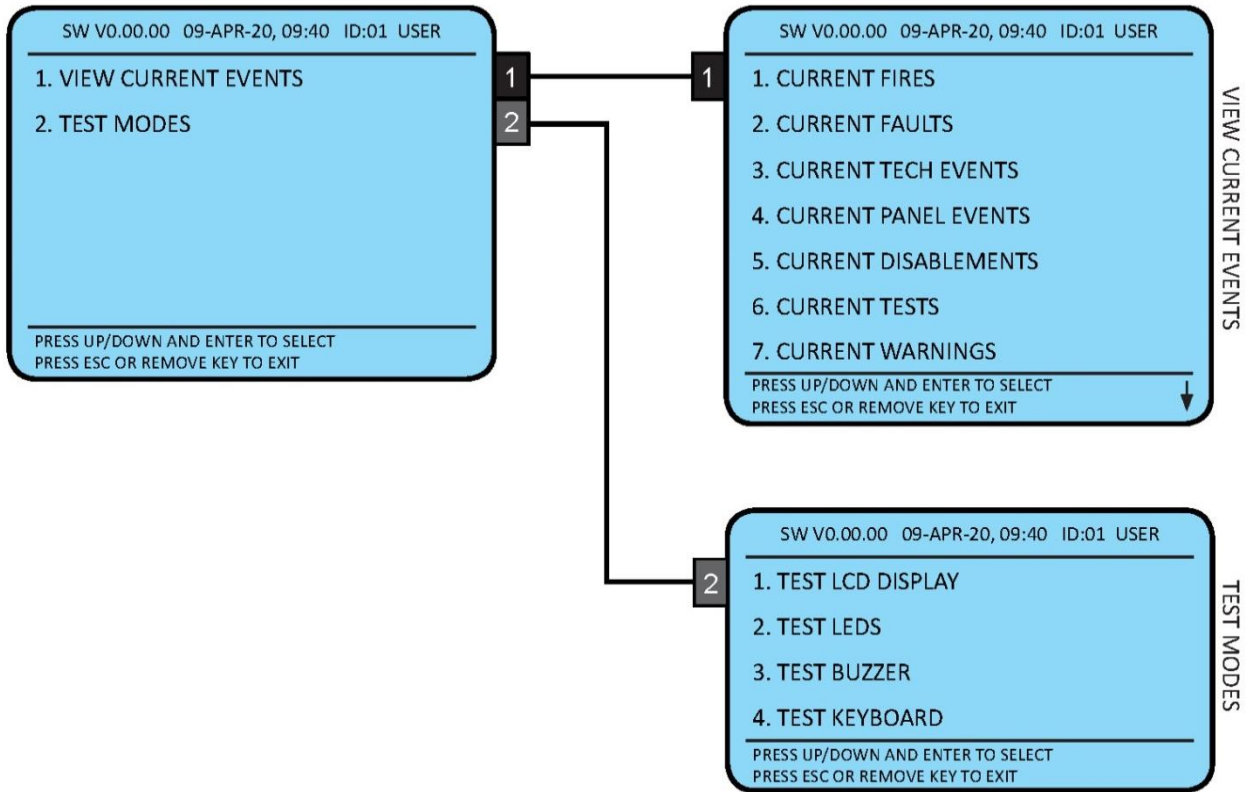

1. View Current Events

▼
Current events show the current state of the system and can be viewed in the current events menus.

2. Test Modes

▼
The Test Modes function causes the panel LEDs to illuminate, the LCD screen to blacken, the panel buzzer to sound and key pad to be tested in order to verify their correct operation.

Press the **Esc** key to exit to the previous menu.

Access Level 2 (Supervisor - 7877): Controls Enabled LED flashing slowly

At Access Level 2 (Supervisor), the main **Fire Alarm Controls** are enabled, and the following **System Controls** are accessible:

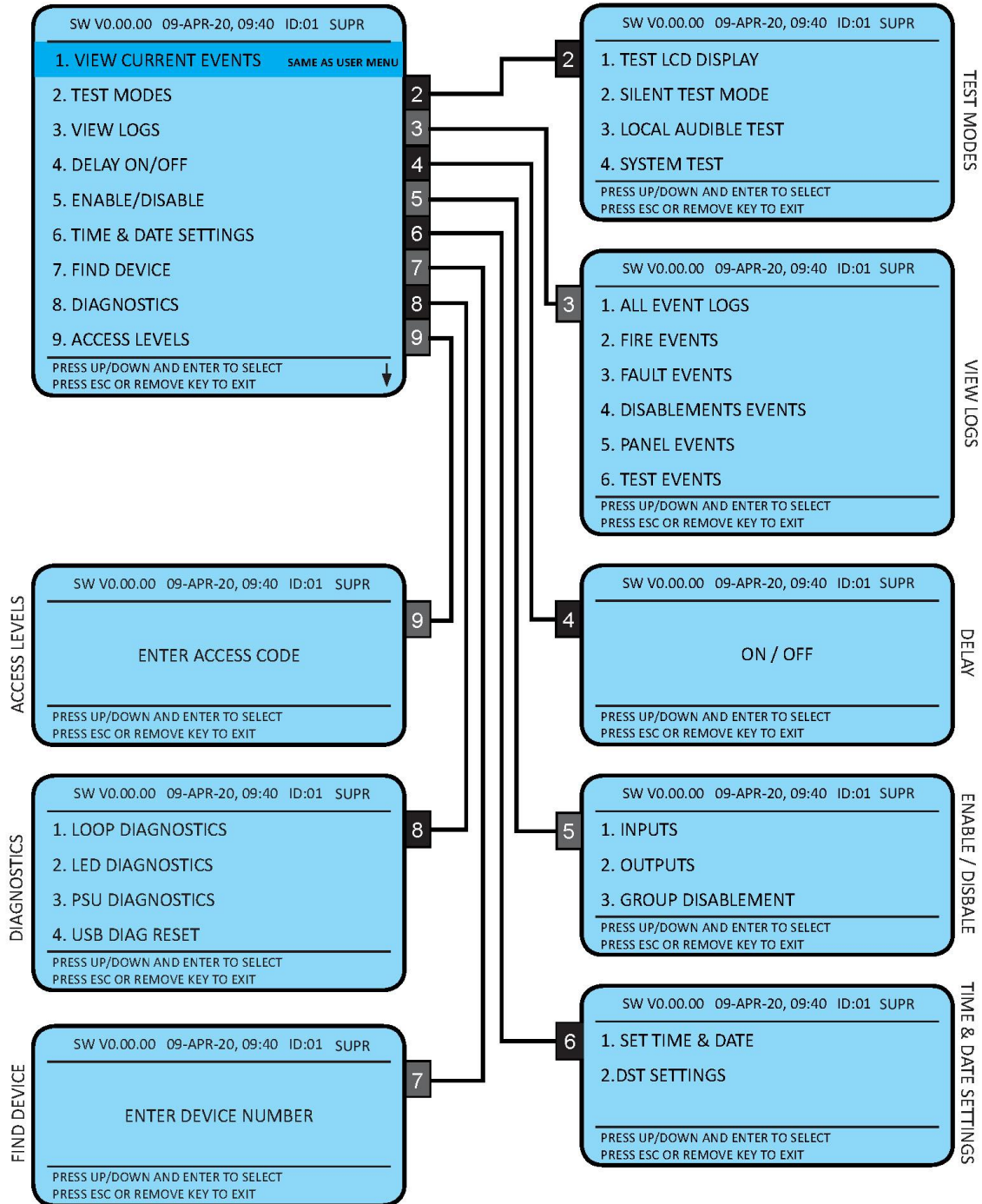

1. View Current Events – Same as USER access page 33

2. Test Modes



Test Modes → Test Controls & Display

The Test Modes function causes the panel LEDs to illuminate, the LCD screen to blacken, the panel buzzer to sound and the keypad to be tested in order to verify their correct operation.

Test Modes → Silent Test Mode

The Silent Test function allows the selection of one or more detection-zones to operate in a 'silent one-man walk test mode'. On triggering a device the device LED operates and the event is recorded into the event log as a test activation, but the sounder does not sound and the control panel does not show an alarm. After approximately 5 seconds the system will reset the device, and another device may be tested. The control panel event log will indicate that a test mode has been selected.

Test Modes → Local Audible Test

The Local Audible Test function allows the selection of one or more detection-zones to operate in a 'one-man walk test mode with local sound'. On triggering a device the device LED operates, the sounder within that device operates and the event is recorded into the event log as a test activation, but the control panel does not show an alarm. After approximately 5 seconds the system will reset the device, and another may be tested. The control panel event log will indicate that a test mode has been selected.

Test Modes → System Test

The System Test function allows the entire system to operate in a simple one-man walk test mode. On triggering a device the device LED operates and the event is recorded in the event log, all the assigned sounders operate for 10 seconds and the control panel indicates an alarm. After approximately 10 second the system will reset the device, and another may be tested. The control panel event log will indicate that a test mode has been selected.

Please note, with the system test mode, only the sounders assigned to operate from that device will sound, and any delays will still be present. ie. if a delay of 2 minutes is present, the system will have been reset before the sounders activate.

Please note, with the system test mode, only the sounders assigned to operate from that device will sound, and any delays will still be present. ie. if a delay of 2 minutes is present, the system will have been reset before the sounders activate.

3. View Event Logs

The all event log keeps up to 1000 historic events. Options 2 to 6 sort the all events log into fire, fault, disablements, panel events & test events. This makes it easier to find specific types of event without having to look through the whole event log.



View Event Logs → All Event Log

The All Event Log will display all events. These are displayed in text format and may be scrolled through by pressing the **UP** and **DOWN** keys.

View Event Logs → Fire Events

The Fire Event Log will display all fire events. These are displayed in text format and may be scrolled through by pressing the **UP** and **DOWN** keys.

View Event Logs → Fault Events

The Fault Event Log will display all fault events. These are displayed in text format and may be scrolled through by pressing the **UP** and **DOWN** keys.

View Event Logs → Disable Events

The Disabled Event Log will display all disablement events. These are displayed in text format and may be scrolled through by pressing the **UP** and **DOWN** keys.

View Event Logs → Panel Events

The Panel Event Log will display all panel events. These are displayed in text format and may be scrolled through by pressing the **UP** and **DOWN** keys.

View Event Logs → Test Events

The Test Event Log will display all test events. These are displayed in text format and may be scrolled through by pressing the **UP** and **DOWN** keys.

4. Delay Override

The Delay Override function overrides any programmed delays. Reset System will automatically re-enable the delay.

To comply with EN54-2 Clause 7.11.1d, a non-delayed manual call point (MCP) should be located next to the CIE to override the delayed output by a manual operation.

5. Enable / Disable



Inputs → Detection Zone

This function allows the disablement or enablement of a detection-zone. Thus, all the input devices (Manual Call Points, detectors and inputs) within that detection-zone will be disabled. The control panel will indicate that disablements are present, a disablement event will be recorded in the log, the device LED will still operate when activated and an event will be recorded in the log, but no programmed actions will occur. The sounder within the device will still operate if triggered from elsewhere on the system.

Inputs → Device

This function allows the disablement or enablement of an individual device. The control panel will indicate that disablements are present, a disablement event will be recorded in the log, the device LED will still operate when activated and an event will be recorded in the log, but no programmed actions will occur. The sounder within the device will still operate if triggered from elsewhere on the system.

Inputs → All Detection Zone

This function allows the disablement or enablement of all detection-zones. Thus, all the input devices (Manual Call Points, detectors and inputs) will be disabled. The control panel will indicate that disablements are present, a disablement event will be recorded in the log, the device LED will still operate when activated and an event will be recorded in the log, but no programmed actions will occur. The sounder within the device will still operate if triggered from elsewhere on the system.

Inputs → All Devices

This function allows the disablement or enablement of all devices. Thus, all the input devices (Manual Call Points, detectors and inputs) will be disabled. The control panel will indicate that disablements are present, a disablement event will be recorded in the log, the device LED will still operate when activated and an event will be recorded in the log, but no programmed actions will occur. The sounder within the device will still operate if triggered from elsewhere on the system.

Outputs → Sounders

This function allows the global disablement or enablement of all the sounders on the system. The control panel will indicate that disablements are present and a disablement event will be recorded in the log.

Outputs → Fire Outputs

This function allows the global disablement or enablement of all fire outputs on the system. The control panel will indicate that disablements are present and a disablement event will be recorded in the log.

Outputs → Fault Outputs

This function allows the global disablement or enablement of all fault outputs on the system. The control panel will indicate that disablements are present and a disablement event will be recorded in the log.

Group Disablement

This function allows the disablement or enablement of the group. The group is fixed and will disable all Sounders, Fire outputs & Fault outputs. The control panel will indicate that disablements are present and a disablement event will be recorded in the log.

6. Set Time & Date



Set Time & Date.

This allows the time and date to be adjusted.

DST Settings.

This allows the Daylight Saving Time to be adjusted.

7. Find Device

This function allows the user to switch on the LED and sounder (if they are present) at any device on the loop in order to aid in locating its position. It cannot be used to turn on the LED of I/O Modules, since this would also turn on the output which would not usually be desirable.

Up, Down and Esc options allow the adjacent devices to be located, and the test to be ended.

8. Diagnostics

There are four types of diagnostics on the Single Loop Panel, a Loop diagnostics, a PSU diagnostics, an LED diagnostics & Peripheral Bus diagnostics. All four come out of the User USB port on the back board. The LED diagnostics will send the CIE LED status to the PC based diagnostic software.



Diagnostics → Loop Diagnostics

This turns the loop diagnostics on or off. This must be set to on for the PC based diagnostic software to get data from the loop.

Diagnostics → LED Diagnostics

This turns the LED diagnostics on or off. This must be set to on for the CIE LED status data to be sent to the PC based diagnostic software.

Diagnostics → PSU Diagnostics

This turns the PSU diagnostics on or off. This must be set to on for the PC based diagnostic software to get data from the PSU.

The PSU Information screen will display PSU status on the Panel screen. The following information will be displayed:

- Charger State Normal
 Charger Fault
 Battery Internal Resistance Fault

- PCB Temperature Normal
 Low Temperature
 High Temperature

- Battery Supply Normal
 Low Voltage
 Lowest Voltage
 Over Voltage

- Battery Temperature Normal
 Low Temperature
 High Temperature

- Mains Supply Normal
 Low Voltage
 Over Voltage

- Earth Fault Voltage The normal voltage between **0V** and Earth SCRN is **1.7V**
 The panel will display an earth fault if this voltage is below **1V** or
 above **2.5V**. The panel can detect a leakage between 0V to Earth
 and between +Ve to Earth.

Diagnostics → Peripheral Bus Diagnostics

This shows what RDUs are programed in the OSP and what is on the Bus with error checking.

Diagnostics → USB DIAG RESET

This resets the USB port for OSP programming.

9. Enter Access Code

This allows the Engineer code to be entered to access the (ENGR) Engineer access level.

Access Level 3 (Engineer - 3647): Controls Enabled LED flashing quickly

At Access Level 3 (Engineer), the main **Fire Alarm Controls** are enabled, and the following **System Controls** are accessible:

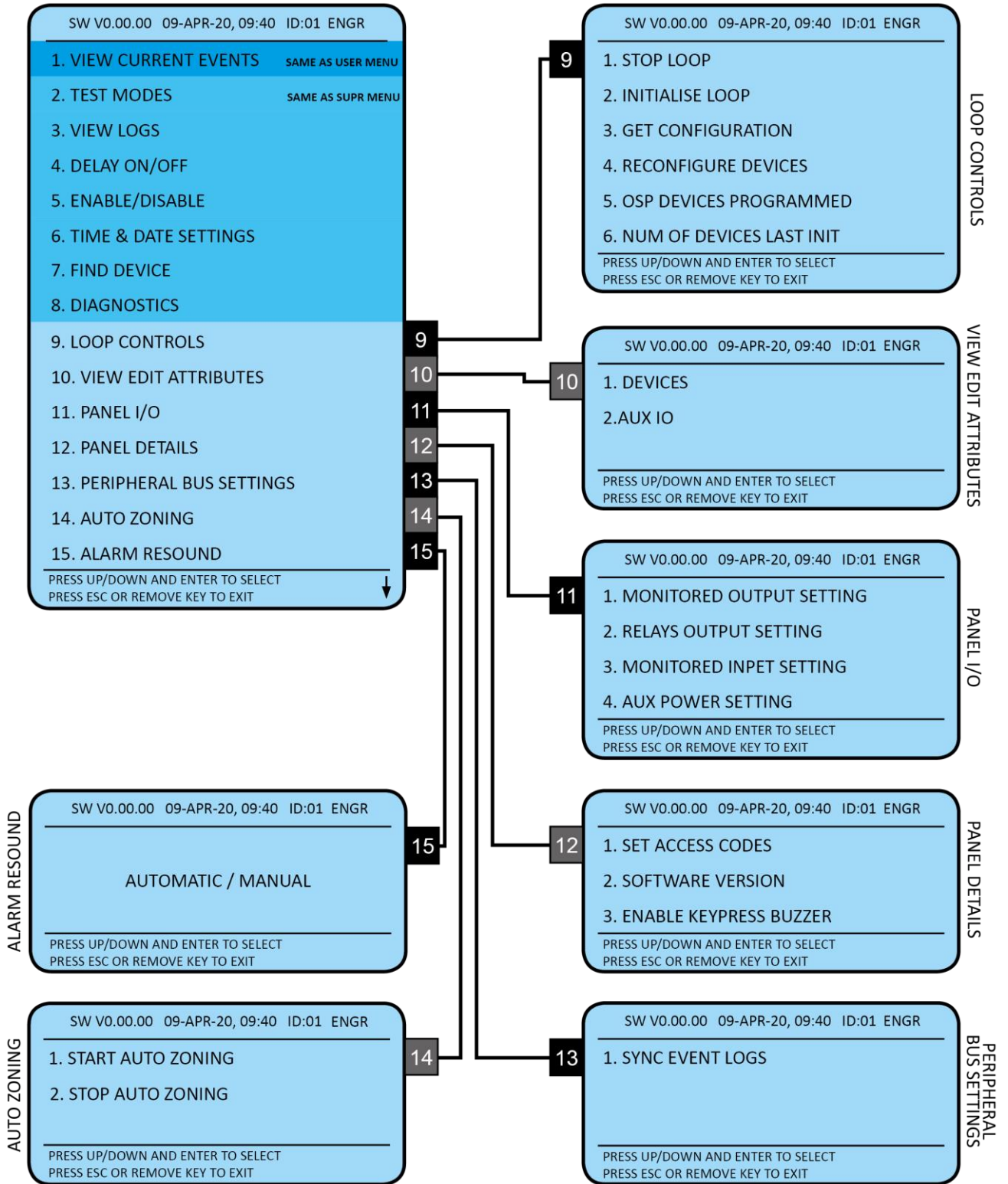

9. Loop Controls



Loop Controls → Stop Loop

This function performs a complete shutdown of every device on the loop. To ensure that every device is properly shutdown, it is important to stop the loop before removing power from the loop. If this is not done, it may cause random faults and stoppages during subsequent initialisation. The loop must also be stopped before removing/adding/replacing devices. Should problems occur during initialisation, stop the loop and wait for approximately five minutes before initialising the loop again. The previously improperly shutdown device should reboot successfully.

Loop Controls → Initialize Loop

This function instructs the control panel to perform its addressable circuit initialisation, or to auto learn the loop devices. Previous loop configuration data is overwritten. It starts this process from Circuit End 1 and collects data on device type, position & serial number, and allocates a Device Address. Please note that even though this panel does not support spurs, the control panel will still check for their presence. Always wait at least 3 minutes between stopping a loop and reinitialising.

Loop Controls → Get Configuration From Device

The control panel processor memory holds all the system configuration and programming details. Certain aspects such as device description, zoning and 'cause & effect' are operated from that point. However, whilst individual device attributes such as smoke mode, heat mode, sound pattern and volume are stored in the control panel, they need to be stored in the processor memory within the device to be operational. The get configuration command collects the configuration from the loop devices to be stored at the control panel.

Loop Controls → Reconfigure Devices

The control panel processor memory holds all the system configuration and programming details. Certain aspects such as device description, zoning and 'cause & effect' are operated from that point. However, whilst individual device attributes such as smoke mode, heat mode, sound pattern and volume are stored in the control panel, they need to be stored in the processor memory within the device to be operational. This is carried out with the reconfigure command, which sends out all the relevant data to the loop devices.

Note that the system should always be re-configured after a PC download from the OSP, and then the system should be reset using the 'reset' button. If this is not carried out the system may give a Configuration Data Error fault.

Loop Controls → OSP Devices Programmed

This function allows the user to view the loop devices programmed and compare with the loop devices present.

Loop Controls → Number Of Devices Last INIT

This function allows the user to check the number of devices initialised on the system. This can be compared with the site information to check all the devices have been initialized by the panel.

10. View Edit Attributes



View Edit Attributes → Device

This function allows the user to view, and edit if required, the attributes for each loop device. These attributes include the device type, serial number, address, zone, description, input, output, detection and alarm information. You may also read the optical and heat standing levels for Multipoint detectors. If changes are made, the individual device may be reconfigured to save the longer task of reconfiguring all devices on that loop.

View Edit Attributes → AUX I/O Device

This function allows the user to view and edit the attributes of the auxiliary inputs and outputs of the devices on the loop.

11. Panel I/O



Panel I/O → Monitored Output Settings

This will allow the engineer to view or change the operation of the Monitored O/P settings. Monitored outputs can be programmed as follows.

- NOT CONFIGURED – O/P will not be active.
- SOUNDER OUTPUT – Operation of O/P will mimic that of a conventional sounder circuit and will de-activate on silence.
- FIRE OUTPUT – Operation of O/P will mimic that of a fire circuit and will de-activate on reset.
- COMMON FAULT – O/P will active when there is a fault on the panel.
- SOUNDER OUTPUT CADENCE - Operation of O/P will mimic that of a conventional sounder circuit but the voltage out will pulse every 500ms and will de-activate on silence.

Panel I/O → Relay Output Settings

This will allow the engineer to view or change the operation of the Relay O/P settings. The Fault Relay (Relay Output 3) will be fixed as a fault relay and cannot be altered. Relay Outputs 1 & 2 can be programmed as follows.

- NOT CONFIGURED – O/P will not be active.
- FIRE OUTPUT (COMMON) – Common Fire output where the relay is energised in the fire condition and will remain so until the system is reset.
- ZONE IN FIRE OUTPUT (ZONAL) – A Zonal Fire Output (a zone must be specified in the range 1-32) is activated by a Fire in the specified zone. The relay is energised in the fire condition and will remain so until the system is reset.
- COMMON FAULT – O/P will active when there is a fault on the panel.

Panel I/O → Monitored Input Settings

This will allow the engineer to view or change the operation of the Monitored I/P settings. Monitored Inputs can be programmed as follows.

- FIRE EVENT – I/P activation will mimic that of a remote fire input.
This can be set as:
 - Full Fire, Latching
 - Full Fire, Non-Latching

- CONTROL EVENT – I/P activation will mimic that of a panel control. The following controls can be set:
 - Silence Alarms
 - Reset System
 - Sound Alarms
 - Silence Buzzer

- TECHNICAL EVENT – I/P activation will sound alarms but not put the panel into a fire condition. This can be set as:
 - Latching
 - Non-Latching

- CLASS CHANGE EVENT – I/P activation will sound alarms only
This can be set as:
 - Latching
 - Non-Latching

Panel I/O → Aux Power Settings

This will allow the engineer to switch on or off the Aux power output.

This can be set as:

- Off
- On
- Resettable - Reset System will cause the Aux Power to reset

12. Panel Details



Panel Details → Set access Codes

This will allow the engineer to change the access codes for access to the user menus. The default codes are:

Access Level	Description	Default Code
0 – NORM	Normal	N/A
1 – USER	User	8737
2 – SUPR	Supervisor	7877
3 – ENGR	Engineer	3647

Panel Details → Software Version

This active control will allow the engineer to view the version of panel operating software implemented.

Panel Details → Enable Key Press Buzzer

Turns the buzzer on/off when a key is pressed.

13. Peripheral Bus



Peripheral Bus → Sync Event Logs

This will allow the engineer to sync the event logs of the main panel to the RDUs.

14. Auto Zoning



Auto Zoning → Start Auto Zoning

This will allow the engineer to change the zone of loop devices by triggering an alarm. On clearing the alarm the device that entered the alarm condition will take on the newly assigned zone.

Auto Zoning → Stop Auto Zoning

This will allow the engineer to end the Auto Zoning mode.

15. Alarm Re-sound



This function allows the sounders to either re-sound on another alarm or to remain in the silenced mode.

Alarm Confirmation Technology

Alarm Confirmation Technology (ACT) is the process whereby a smoke detector may be configured to issue a localised warning in specific regions, prior to sounding a general alarm. This is generally of great benefit in dwelling areas where smoke, steam or cooking fumes may trigger a detector. **This can only be setup using the PC based OSP software.**

The following drawing demonstrates some of the possibilities:

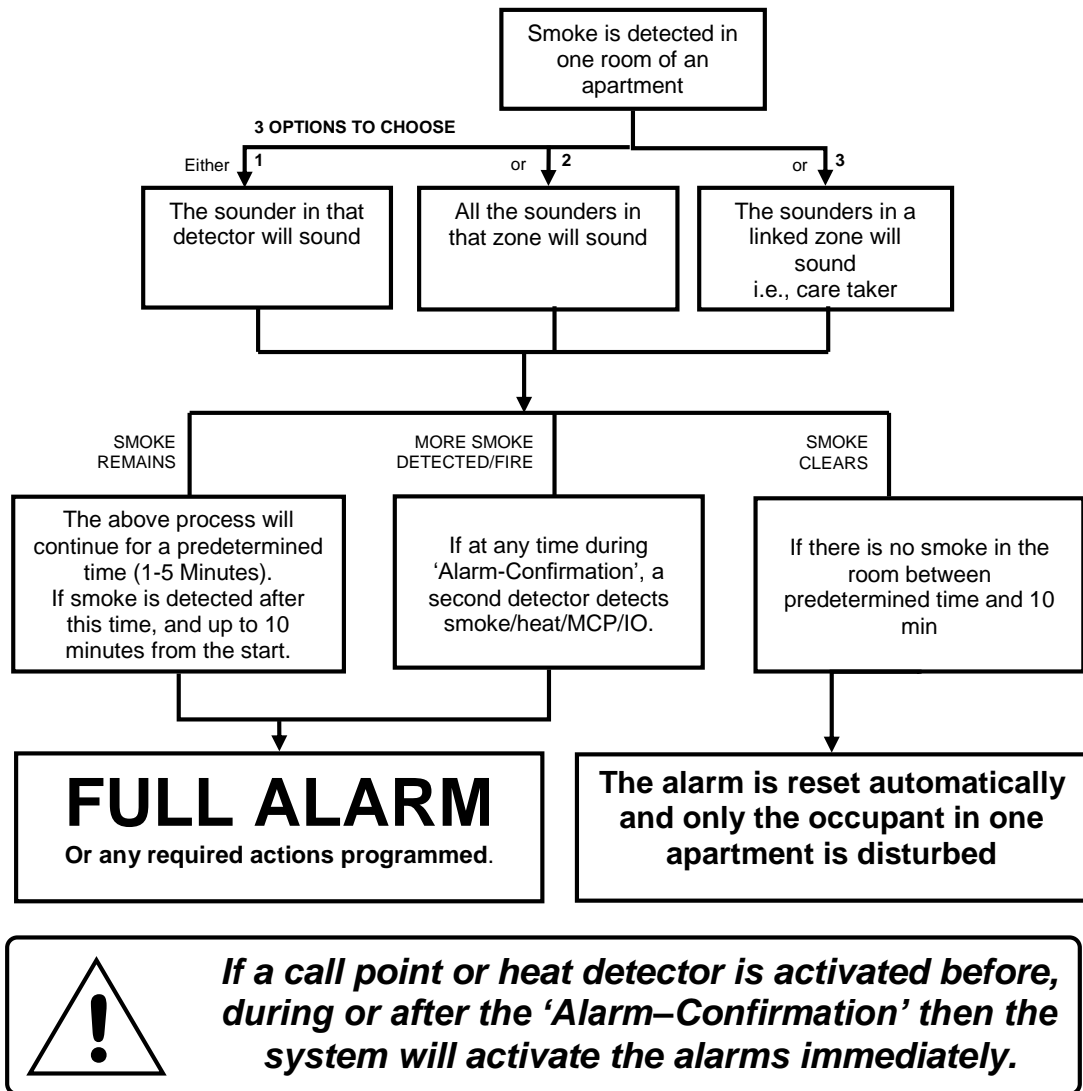

This function affects the smoke detector only, and operates before the control panel enters the Fire state. Thus, the system 'Cause & Effect' does not need to be adjusted as **Alarm Confirmation takes place before the programmed Cause & Effect sequence is reached.**

This function requires the use of a PC with CIE-A-200 OSP and it is not possible to use it without. In order to activate the function, install the devices as normal and refer to the CIE-A-200 OSP Programming Manual for further details.

Alarm Confirmation Delay

The Alarm Confirmation Delay timer allows an automatic reset of an unconfirmed alarm from a smoke detector.

When a smoke detector using Alarm Confirmation is activated, the sounder within that device (or all the sounders in the zone) will activate with the sound pattern selected for Alarm Stage 1 (Alarm Confirmation). This warning sound may also be copied to any additional zone.

At the end of the Alarm Confirmation Delay time the system will check the detector again to see if the activation has cleared. If so then the device will reset and no further action need be taken.

The sounder operates during the chosen Alarm Confirmation Delay time, and stops for the final 20 seconds, during which time the device is reset to check for further smoke presence.

During the Alarm Confirmation Delay, the activation of an additional smoke detector into **Alarm Confirmation** will cause the delay time to cease and an instant alarm to be generated.

If, however, the detector is still in alarm then the entire system will go into alarm, operating all the sounders programmed in the Cause & Effect area.

For a further time period (10 min minus Alarm Confirmation Delay), the activation of the smoke detector will cause an immediate alarm (depending on the programming of the system Cause & Effect).

The activation of any Heat detector (even in the same device as the smoke detector in Alarm Confirmation) generates an immediate alarm (depending on the programming of the system Cause & Effect).

Selecting the Devices

Any smoke detectors which are to utilise **Alarm Confirmation** must be selected using the CIE-A-200 OSP programming software. Smoke detectors not selected will operate in a standard manner (depending on the programming of the system **Cause & Effect**).

An **Alarm Stage 1 (Alarm Confirmation)** sound pattern must also be selected, and this may be set to a different sound pattern to that chosen in **Alarm Stage 3 (Evacuate)** in order to provide an audible difference between alarm stages.

The activation of any smoke detector set for Alarm Confirmation causes the sounder within that device only to operate (or across the entire zone if required), the Alarm Confirmation LED will illuminate on the control panel. The warning sound may also be copied to any additional zone.

The activation of any Heat detector (even in the same device as the smoke detector in Alarm Confirmation) or manual call point generates an immediate alarm (depending on the programming of the system Cause & Effect).

Commissioning

Installation 1st Stage

The installer needs to install the system wiring in the form of 2-core and screen loops returning to the control panel.

The cabling should be 2-core 1.5mm², screened and fire resistant, of FP200 equivalent type. 4-core cable must not be used as a loop 'feed & return' due to the possibility of data corruption.

The loop should be left as a complete loop with no devices connected, and must be tested and documented for conductor continuity and for insulation integrity, with a high voltage tester as required for general electrical installations. If using legacy Sita Multipoint detectors, use the shorting links provided within each base to provide continuity in the positive core.

The control panel back box should be mounted, with the mains supply tested, connected and isolated at the un-switched fused spur, ready for the commissioning engineer.

The installer needs to provide a set of **As-Wired** drawings, completed **configuration sheets** and proof of **loop continuity and insulation test readings** etc., to enable commissioning to proceed. This information is essential for commissioning and programming to proceed, and may be entered onto the forms provided at the rear of the manual.

Installation 2nd Stage

Once the commissioning engineer is satisfied with the continuity / integrity of the loop, the devices may be installed, as in the next section.

NB. *Ensure that the next section, 'Initialisation', is read and understood before the devices are installed.*

Initialisation

The addressable device loops may now be initialised. This is when the control panel interrogates the loops one device at a time, for type, serial number and position, before allocating a loop address number. Initialisation is carried out from the control panel keypad by utilising one of the three loop initialisation commands located within the Access Level 3 (Engineer) menu.

The system can only indicate faults present when the loop is fully initialised. If the initialisation fails then you will need to find faults manually. You may run the initialisation backwards by reversing the loop connections, or one ended by removing one end of the loop. You may also use the CIE-A-200 OSP software to identify which devices have been found and initialised. Noting how far the device count on the control panel screen reached will indicate many faults, such as open or short circuit. Furthermore the sounders may be operated from the control panel to indicate which devices are operational, or the LEDs may be switched on using the appropriate Fike Loop Diagnostic software.

Please note that even though this panel does not support spurs, the control panel will still check for their presence.

Commissioning

Commissioning the CIE-A-200 system involves programming and testing the system.

Whilst the software may be pre-configured before arriving at site if required (from the **as-wired** drawings and the configuration sheets), it is generally simpler and quicker if the site configuration is uploaded and altered directly whilst still on site, as the system will have found much of its configuration upon initialisation.

If the configuration is written before upload from the control panel, then the software is termed a 'New file', and does not contain the entire loop information required (which the control panel acquires on initialisation). This may then be merged on site to give a full configuration file termed an 'Old file'.

A comparison of serial numbers between the drawings/config sheets and the OSP upload is always recommended to prove the actual device order as opposed to the assumed device order.

Normally, commissioning will take place as follows:

1. Initialise the addressable device loop.
2. Upload the configuration from the control panel to the PC with CIE-A-200 OSP.
3. Check that the addressable device serial numbers are in the positions on the loops that were expected, amend the configuration to suit the site and check it carefully.
4. Download the configuration from the PC to the control panel.
5. Reconfigure the addressable devices with the Reconfigure command at Access Level 3 (Engineer).
6. Reset the system
7. Test for correct operation.

NOTE: It is imperative that the correct version of OSP is used to match your version of CIE-A-200 control panel. The use of an incompatible version may result in incorrect operation of the control panel.

When the system is correctly programmed it must be tested for correct operation. It is important to remember that the panel test modes are service tools and not a commissioning tool, as the complete 'cause and effect' of the system is not tested.

The System Test function allows the control panel to be completely activated as normal, before the control panel automatically silences and resets the system. However, it is recommended that a new system is commissioned live, with all sounders active in order to prove correct operation of every device whenever a system is programmed in any other way than a simple 'One off, all off' configuration.

It is essential that every device is tested in every selected mode of operation, and that all programmed actions are observed for correct operation. This includes the smoke testing of smoke detectors, heat testing of heat detectors, testing of Manual Call Points, testing of all inputs, testing of all sounders and outputs.

We also recommend that all devices, which are set to 'heat only', are tested for smoke operation, to ensure that the smoke detection has been correctly disabled.

Configuration Example

From your 'As-Wired' drawings device addresses can be assigned, starting from circuit end 1.

From this the device attributes may be filled out on the configuration sheets, as shown in the following example:

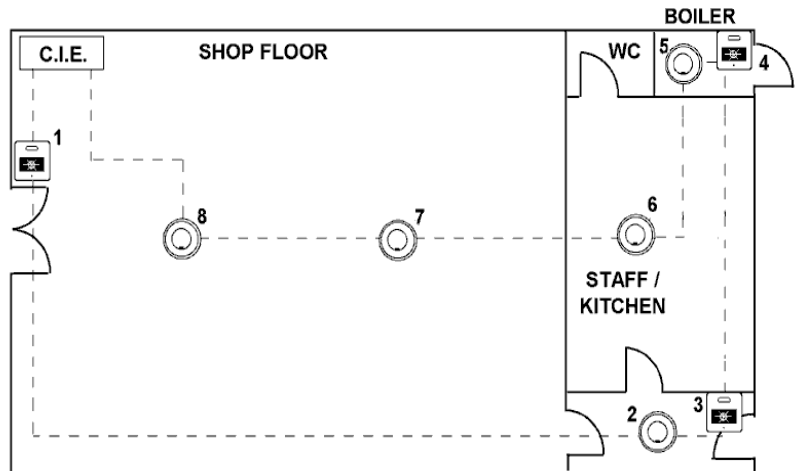

Control Panel No.: 01	Loop No.: 1
Description: West Wing	Description: Ground Floor

DEVICE ADDRESS	SERIAL NUMBER	DEVICE DESCRIPTION (24 CHARACTERS MAX)	ZONE	DEVICE TYPE	SMOKE MODE	HEAT MODE	ALARM CONF'N
1	212	Shop Floor: Main Entrance	1	MCP	-	-	-
2	30960	Staff Area: Rear Lobby	1	MPS	SM2	HM2	-
3	213	Staff Area: Rear Exit	1	MCP	-	-	-
4	214	Boiler Room	2	MCP	-	-	-
5	30959	Boiler Room	2	MPS	SM0	HM3	-
6	30962	Staff Area: Kitchen	1	MPS	SM0	HM2	-
7	30963	Shop Floor: Rear	1	MP	SM2	HM2	-
8	30961	Shop Floor: Front	1	MPS	SM2	HM2	-

These details may then be entered into the CIE-A-200 OSP programming software in order to program the operation of the system.

End User Training

A Fire Alarm System is of little use if the end user and/or the responsible persons who will be present in the building do not know how to operate and respond to the system. It is therefore essential that commissioning includes training for the users of the system and responsible persons.

User instructions and a Zone Chart should be left adjacent to the control panel. As access to the system must be controlled by responsible persons, it would be unusual to display the access codes on this notice. These codes must however be available for the responsible persons, so ensure that they are notified correctly.

The CIE-A-200 User Guide should be explained and left with the responsible person on site, for storage in an accessible and known location, in order that the responsible person and the service engineer may keep information records up to date.

Good Practice

The following suggestions are good practice if carried out during commissioning, and may help avoid common problems at a later date. The Fike Safety Technology Technical Support department may be unable to assist if the information is unavailable, and the guidelines not followed.

Number of Devices

Make a clear note in the control panel back box in a conspicuous position of the number of devices on the system.

In the event of any future visits to site it will be clear how many devices are expected if the system is initialised. Without knowing this it is not possible to be sure that all devices have initialised correctly.

Label the Loop Ends

Make a clear note on the loop cables attached to the terminal block to show **LOOP END 1** and **LOOP END 2**.

Thus, if the addressable device loop is reversed for any reason it will be plainly visible from the labels.

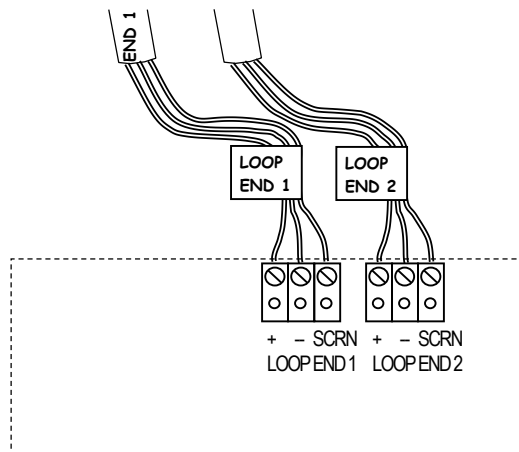

Note the Loop Readings

Make a clear note in the control panel back box of the loop continuity and insulation resistance readings, including those for the screen and mains earth.

These are then available for fault finding at a later date, ie.

Date	+/+	-/-	Scr/Scr	+/-	+ /Scr	- /Scr	Earth/Scr	Engineer
23/04/19	9.7	9.6	6.3	OL	OL	OL	OL	J Williams
30/09/19	10.3	10.2	6.4	OL	OL	OL	OL	T Roberts

Configuration Printout and Drawings

Make a **Text Report** printout of the system configuration from CIE-A-200 OSP and store it safely on site along with an up to date site plan marked with devices, serial numbers and wiring order.

If any return visits are necessary all the relevant information on the system will be available without having to carry out an Upload of data to the PC. This includes address, serial number, device configuration and zonal configuration data.

Initialisation

Normal Readings

Ensure that your addressable device loop has the correct continuity and insulation integrity. With a digital test meter there should be a continuity reading of approximately 1.2 ohms per 100m of 1.5mm² cable, and no continuity should be read between cores.

With the loop stopped and the loop connector block removed from the control panel, measure the continuity between **Loop End 1 –ve** and **Loop End 2 –ve**. There should be a maximum resistance of approximately 24 ohms, equating to approximately 1.2 ohms per 100 metres.

Likewise measure the continuity between **Loop End 1 Scrn** and **Loop End 2 Scrn**. There should be a maximum resistance of approximately 24 ohms, and this reading will normally be slightly lower than that of the **Loop –ve** continuity, due to the greater surface area of the screen. Screen integrity is of critical importance.

A measurement of the continuity between **Loop End 1 +ve** and **Loop End 2 +ve** should show a very high resistance, as the isolator within each device only provides continuity when energised by the control panel.

Measuring the insulation resistance between the **Loop –ve** and the **Loop Screen** should show no continuity. Remember that a low voltage electronic test meter should be used, and its accuracy is likely to be low when measuring high resistances, but this will give enough information to show insulation integrity.

Do not use a high voltage insulation test meter whilst any devices or the control panel are connected as they will suffer damage.

Initialisation Process

When the control panel is powered up the following LED will be continuously on, and the addressable device loop must be initialised at Access Level 3 (Engineer).

DISABLED ●

During initialisation, a screen similar to the following will be displayed.

INITIALISING LOOP					
Loop Dev		Spur Dev		Complete	
23	✓	0	✓	23	✓

The number shown under **Loop Dev Init** gives a count of the number of devices initialised on the loop. If the loop is found to be complete this is followed by a tick, whereas if the loop is found to be incomplete this is followed by a cross.

The number shown under **Init Complete** gives a count of the total number of devices initialised on the system. If initialisation is completed correctly this is followed by a tick, whereas if there is any failure in initialisation this is followed by a cross.

In normal initialisation conditions the control panel will start from Loop end 1, find, interrogate and address each device on the loop one at a time. When the second end of the loop is reached the control panel will display a tick or cross as shown above to indicate whether or not a complete loop was found.

Finally the control panel will investigate any spur connections from Multipoint detectors. Spurring was a feature in earlier panels and devices which allowed up to 5 devices to be spurred from a Multipoint detector over a 20m distance (total). The overall maximum permissible cable distance of 2km for an addressable circuit included both the main loop and any such spur runs and up to 5 spur runs were permitted on the system. **This feature is no longer supported in current panels and devices.** Even though spurs are no longer supported, the devices are still checked as part of the initialisation process for the presence of spurs. The **Spur Dev Init** column should indicate that no spurs are present on the system. If all devices are checked and no spurs are found a tick should be shown. However, if the panel found any spurs during this process, then even if initialisation has completed and a tick is shown, the loop should be stopped and the spurred devices rewired into the main loop.

When all possible devices have been initialised the control panel will indicate either that initialisation is complete or not, and the number of devices found.

The following LED will be extinguished (as long as no other faults exist).

DISABLED ○

Or:

The following LED will remain on:

DISABLED ●

After initialising the loop and pressing ESC to exit the STANDARD INITIALISATION screen, if the number of devices initialised does not match the number of devices programmed, a DEVICE QUANTITY MISMATCH screen will appear. This screen will give details of the number of devices found and the number of devices programmed.

Note that if the panel is new, a device quantity mismatch is likely because the panel will have been tested in the factory with various configurations and will have remembered the final test configuration.

Initialisation Faults

Device Quantity Mismatch

A device mismatch will occur if a device or devices have been physically removed from or added to the system and these changes have not been updated in the OSP and downloaded into the panel. The panel will be expecting to find the original number of devices which were downloaded to it. Check the site information to see if any changes have taken place and compare this with the OSP file.

Another cause could be that the loop was initialised too quickly after it was stopped. If a device has not powered down completely it may be missed when the loop is initialised causing a mismatch. Stop the loop and wait at least 5 minutes before reinitialising again.

Loop +ve to –ve Short Circuit Loop +ve Open Circuit

If the system faces a **Loop +ve to –ve short circuit**, or a **Loop +ve open circuit** during initialisation, the initialisation will fail at that point and a message of **Loop not complete** will be displayed.

All devices up to that point will be operational, but devices beyond will not be active, as the control panel will not initialise from Loop End 2 as it becomes very difficult to understand fully where the problem lies.

The active faults list in Access level 2 (Supervisor) and Access Level 3 (Engineer) and will display messages accordingly. These messages need to be viewed together as a complete set.

The control panel cannot determine the location of a short circuit, so a short circuit message will be followed by the location of the open circuit which is created when the isolator in that device responds to the short circuit. Use diagnostics tool to identify the location of the short circuit.

Eg., Loop s/c and Loop o/c at device 'X'

Thus in the **Loop +ve to –ve short circuit** example shown previously, the initialisation will reach device 1 and fail thereafter. Thus the problem is after that point.

An investigation of the next device (device X+1) will determine if a correct loop voltage of approximately 40V DC has reached that point. If this has happened then the problem lies in either the connections at that point (device X+1) or a faulty electronics module (device X+1).

If the correct loop voltage of approximately 40V DC is not present at the next device (device X+1) then stop the loop and investigate device X. The problem may be due to an incorrect connection, a cable fault or a faulty electronics module.

If it is suspected that a device electronics module or device is faulty then try linking that device out (link the +ve cores together) and reinitialising the loop. If the initialisation then passes that point the device may be replaced. It is not advisable to leave a system with a device missing (positive cores linked together) in this way as all successive devices will be displaced.

The loop must be re-initialised to clear the short circuit fault.

Please note: A short circuit between cores with a value of between 3K and 300 ohm can cause corruption of the data on the loop and although no Short Circuit fault is reported the system integrity will be compromised.

Loop –ve Open Circuit

If the system faces a **Loop –ve open circuit** during initialisation, the initialisation will not fail at that point, but continue as normal to the end of the loop. All devices will be operational (as long as no other faults exist).

A message of **Addressable circuit: -ve open circuit** will be displayed, but the control panel cannot detect where the open circuit fault is located.

In order to locate the fault position, stop the loop, disconnect Loop end 2, wait at least 3 minutes and then reinitialise the system. The initialisation will fail at that point and a message of **Loop not complete** will be displayed.

Thus in this **Loop –ve open circuit** example, the initialisation will reach device X+1 and fail there. Thus the problem is after that point.

An investigation of the next device (device X+2) will determine if a correct loop voltage of approximately 40V DC has reached that point. If this has happened then the problem lies in either the connections at that point (device X+2) or a faulty electronics module (device X+2).

If the correct loop voltage of approximately 40V DC is not present at the next device (device X+2) then stop the loop and investigate device X+1. The problem may be incorrect connection, a cable fault or a faulty electronics module.

If it is suspected that a device electronics module is faulty then try linking that device out (link the +ve cores together) and reinitialising the loop. If the initialisation then passes that point the device may be replaced. It is not advisable to leave a system with a device missing (positive cores linked together) in this way as all future points will be displaced.

The loop must be re-initialised to clear this fault. Always wait at least 3 minutes between stopping a loop and reinitialising.

Device Faults

If the system detects a **device fault or fire activation** during initialisation, the initialisation will not fail at that point. All devices will be operational (as long as no other faults exist).

However, the system can only ignore a certain amount of fire or fault data until initialisation is complete, and beyond certain limits initialisation will fail and the various fault or fire activations will be displayed.

In either case, the event generated should be dealt with before the loop is reinitialised.

Firstly, investigate and rectify any fire activations which are displayed. These may vary from Manual Call Points which have not been reset, to Multipoint detectors which are contaminated.

Secondly, investigate and rectify any fault conditions which are displayed. These may vary from 'Input open circuit', to a Multipoint detector with its optical chamber loose (indicating signal low).

The system may then be reinitialised and commissioned as required.

It is important that devices (or chambers in earlier devices) are removed/replaced only with the loop stopped.

Earth Faults

General

If the control panel detects a short circuit or leakage current to earth/screen from one of its supply rails (either 0V or +Ve) an **Earth Fault** will be displayed.

The voltage between 0V and Earth SCRNs can be checked with a DVM. The normal voltage is 1.7V. The panel will display an earth fault if this voltage is below 1.5V (caused by current leakage to 0V) or above 2.5V (caused by current leakage to +Ve).

Remove the circuit cables connected to the control panel one at a time and reset the system. When the circuit with the earth fault is disconnected, the earth fault will clear within approximately 30 seconds of being reset.

Note that if a computer is connected to the control panel, an earth fault may be generated at the control panel. If the connection is permanent, an optical isolator must be used between the PC and the control panel.

A short circuit (low resistance: expected to be less than 5Ω) may be identified and tracked with a digital test meter between either the positive core or the negative core and the screen of that circuit.

It is not possible to override the earth fault monitoring as it is important for correct system operation.

If it is shown that the earth fault is on the addressable device loop, then disconnect it from the control panel and investigate it with a digital test meter.

Loop –Ve to Screen

If the fault is a **short circuit from screen to loop –Ve** then it will be easily identified and rectified with a digital test meter.

An investigation of the resistance reading between loop –Ve and earth/screen at the control panel for each end of the addressable device circuit should give a good indication of the location of the short circuit.

Eg, if the resistance reading at Loop end 1 were 9 ohm, and at Loop end 2 were 3 ohm then it may be estimated that the short circuit lay approximately $9/(3+9) = \frac{3}{4}$ of the way round the addressable device circuit from Loop end 1. Investigating that area, and introducing a split to the Loop –Ve as required, will allow it to be tracked and rectified.

Loop +Ve to Earth

If the fault is a **short circuit from screen to loop +Ve** then it will only be identified with a digital test meter at that individual length of cable due to the inbuilt short circuit isolators in each device.

To locate this manner of fault, split the +Ve core of the loop at approximately a half-way point on the loop, then reinitialise with only Loop End 1 connected to the control panel.

Even though the initialisation will fail due to the enforced open circuit, the earth fault will only be indicated if it is located within the section of the cable which was initialised. The split may then be reinstated in another position and the process continued, until the section of the system suspected of containing the earth fault is small enough to allow each portion of cable to be individually tested with a digital test meter.

General Fault Finding

Common Faults

In the event that inexplicable or random faults continue after any obvious indication has been dealt with, take the following steps.

1. Verify that the addressable device loop cable readings are correct and suitable. Take particular note of the screen resistance and rectify any faults found. Ensure also that there is no connection from the screen to earth in the building other than at the relevant terminals at the control panel.
2. Also check for connection from screen to the building structure which may not be earthed (eg. concrete, plaster, suspended ceilings) as such connections can inject noise into the screen causing communication problems.
3. Ensure the correct number of devices has been initialised by checking at Access Level 3 (Engineer) for the number of devices found on the last initialisation, and compare that with the number of devices programmed onto the system.
4. Ensure that Loop End 1 and Loop End 2 are connected correctly and not running in reverse.
5. Reconfigure the addressable devices using the reconfigure prompt at Access Level 3 (Engineer), then reset the system and test it. (only if all devices are found)
6. Check all devices for loose connections, broken copper connecting strips in the connector, broken connector bodies.

Intermittent and Recurring Faults

Smoke Sensor Failed – Signal High

Ensure that the correct device is being investigated by comparing its description with the device address, and / or the serial number.

Do not remove or add devices with the loop active.

Ensure that the Optical Chamber is clean, if not then replace it with a new one. If the problem still exists consider changing the electronics module.

Note that the Sita ASD detector has the electronics module and chamber integrated into a single one-piece housing. This unit should be replaced as a complete assembly if either the chamber or electronics module require changing.

The loop MUST BE STOPPED & RE-INITIALISED when changing optical chambers and detectors.

Device Faults

If the system detects a **device fault or fire activation** during initialisation, the initialisation will not fail at that point. All devices will be operational (as long as no other faults exist).

However, the system can only ignore a certain amount of fire or fault data until initialisation is complete, and beyond certain limits initialisation will fail and the various fault or fire activations will be displayed.

In either case, the event generated should be dealt with before the loop is reinitialised.

Firstly, investigate and rectify any Fire activations which are displayed. These may vary from Manual Call Points which have not been reset, to Multipoint detectors which are contaminated.

Secondly, investigate and rectify any fault conditions which are displayed. These may vary from 'Input open circuit', to a Multipoint detector with its optical chamber loose (legacy Sita Multipoint only) indicating signal low.

Please note: A short circuit between cores with a value of between 3k and 300 ohm can cause corruption of the data on the loop and although no Short Circuit fault is reported the system integrity will be compromised.

The system may then be reinitialised and commissioned as required.

Loop Open Circuit

If random or recurrent Loop O/C faults are reported then check the entire system for the following:

Loose connections. Ensure all terminals are tight.

Broken Connectors. If the terminal is over-tightened the main body of the connector may become broken, causing an intermittent open circuit.

Broken or missing copper connecting strips (Original style Multipoint only – not ASD). The connection from the connector body to the pin which links to the Multipoint detector is made by the copper connecting strip which may be seen entering the connector with the cable. Ensure that these are not broken off or bent out of place as this will cause an intermittent open circuit.

Broken cables. Ensure that the cables are not snapped off before they enter the connector.

A cable may seem to be connected, but not actually make a contact.

Trapped insulation. Ensure that the cable insulation is not trapped in the connector, stopping it from making a connection.

The entire system should be carefully checked for the above, as a cumulative effect may take place if a number of high resistance connections are present, causing random reporting of the location of the problem.

IMPORTANT NOTE

If short circuit or open circuit faults occur on the loop wiring the panel will detect these faults and indicate this with the yellow loop fault LED. These faults will also get logged in the event logs.

The adjacent devices on the loop will open their isolators to isolate the section of cable which is in fault. The panel will use both ends of the loop to communicate with the devices so no devices are lost.

In these cases as no devices are lost the faults may appear to clear but it is most important to check the fault LEDs and event logs on the panel.

When cable faults occur, the loop **MUST BE STOPPED** manually and the faults investigated and rectified before re-initialising the loop again. Do not attempt to rectify a cable fault or to remove and/or reinsert devices into a live loop.

Some loop devices may be lost under certain short circuit/open circuit conditions depending on the nature and position of the fault. Any devices affected will be reported as in fault on the panel.

Note: When the devices open their isolators due to loop faults, the device isolators are latched. The loop MUST BE STOPPED & RE-INITIALISED in order to close the device isolators and reset the devices to a normal operating condition. If this is not done, a second cable fault will result in devices being lost from the addressable circuit. Always wait at least 3 minutes between stopping a loop and reinitialising it.

Advanced Connections

Monitored Relays

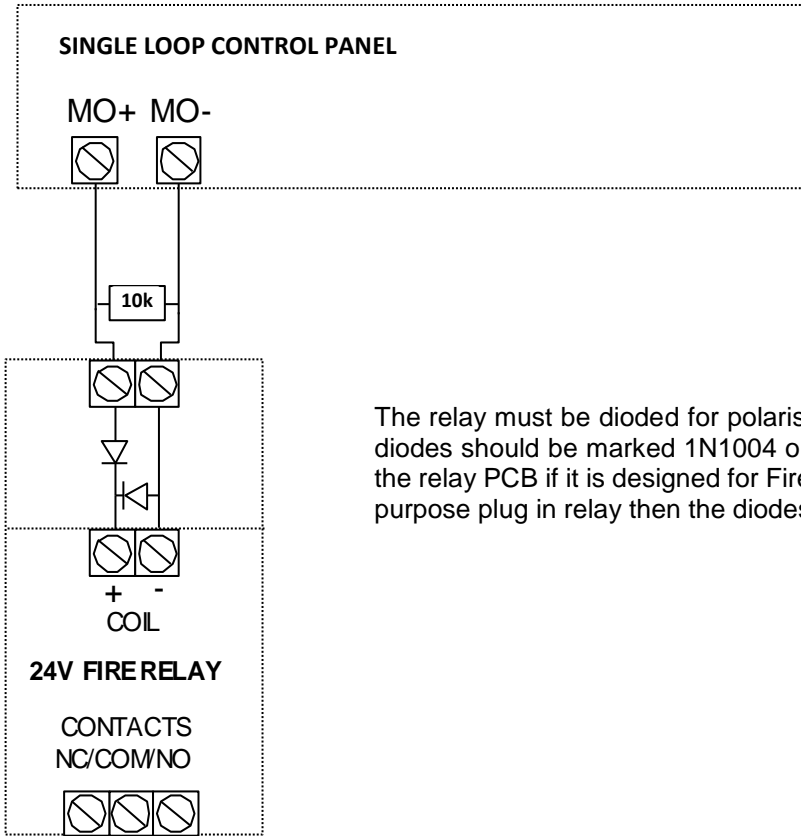

The relay must be dioded for polarisation and suppression as shown. These diodes should be marked 1N1004 or similar, and may already be located on the relay PCB if it is designed for Fire Alarm Systems. If the relay is a general purpose plug in relay then the diodes may need to be added externally.

Technical Data

Control Panel

		CIE-A-200 Control and Indicating Equipment
Dimensions	W x H x D	353mm x 333mm x 117mm
No. of zones		32 zones
Number of loops		1 Loop
No of devices	Maximum of 200 devices <i>or</i> maximum of 450 DLUs per loop	(whichever is reached first)
Device labels		31 characters
LCD display	Graphic display Field 1 (top) Field 2 Field 3	Control Panel Information Window Active Information Window Prompt Window
LED Indication	Fire / Zone LEDs Fault LEDs Delay Disabled Test Power	Red - steady in fire Yellow - continuous Yellow - continuous Yellow - continuous Yellow - continuous Green - continuous for power on
Audible Indication	2.5kHz Buzzer	Continuous in fire Intermittent (700ms on, 300ms off) in fault
Keypad	4 way dedicated 17 way alphanumeric	Fire Alarm Controls System Controls
Event log		1000 events
Inputs and Outputs	Relay Outputs x3 Monitored Outputs x2 Monitored Inputs x2	Volt free contacts SPCO 30V DC @ 1A max per contact 2 x 24V conventional monitored outputs Fire, Fault, Signal, Technical Alarm 10k EOL, 500mA max per circuit 2 x resistance monitored inputs 3k3 EOL, 680R or 470R firing resistor
Auxiliary Power Output	Working Range	20 - 31V DC 450mA
Power Supply	Working Range Ri max I min I max a I max b Battery Charging Voltage/Current Details	21 - 33V DC 150W 1R (max internal battery resistance) 82.3mA (min output current) 626.99mA (max output current) 2.13A (max output current) 27.3V @ 21°C, temperature compensated -5°/+40°C, max charge current 1.2A
Mains Supply Input		230V AC Nominal
Nominal Loop Operating Voltage		40V DC
Max loop current		500mA
Environmental Data	IP Rating IP30	Ambient Temp Range +5°C to +40°C

Note: Refer to the relevant sections in the manual for full details of input and output ratings.

Control Panel Fuses and Protection

Single Loop Addressable Panel	
Loop output	1.2A current limiter
Monitored Outputs 1 and 2	750mA trip polyfuse
Auxiliary 24V DC supply	T500mA Time Delayed 20mm Glass
Mains	T4A Time Delayed 20mm Ceramic (in mains terminal block)
Battery Charger	1.2A current limiter
Battery (reverse polarity)	F3.15A Fast Blow 20mm (in line with battery leads) Glass

Note: Refer to the relevant sections in the manual for full details of input and output ratings.

Resistor Colour Codes

On colour coded resistors the band at one end will be spaced further apart than the others. The resistor should be viewed with this band to the right as follows, reading from the left and side of the resistor:

Band	4 Band Codes	5 Band Codes
1	1 st Digit	1 st Digit
2	2 nd Digit	2 nd Digit
3	Multiplier	3 rd Digit
4	Tolerance	Multiplier
5	-	Tolerance

Colour	Digit	Multiplier
Black	0	1
Brown	1	10
Red	2	100
Orange	3	1,000
Yellow	4	10,000
Green	5	100,000
Blue	6	1,000,000
Violet	7	-
Grey	8	-
White	9	-
Gold	-	0.1
Silver	-	0.001

Battery Calculations

Note: An Excel spreadsheet (document no. 26-1765) is available to automatically work out both standby battery calculations and loop loading calculations based on the quantities entered. This includes ratings for legacy devices.

Current draw ratings for the control panel are as follows:

PRODUCT DESCRIPTION		QUANTITY	CURRENT DRAWN (mA)		TOTAL (mA)		Dev	DLUs
Product Code	Description		IS	IA	IS	IA		
520-0001	Single Loop Control Panel	0	44.600	82.3	0.000	0.000		
	Back Light	0	1.000	1.000	0.000	0.000		
	Output 1 (MO1) (MAX 500mA depending on external load) IF USED	0	500.000	500.000	0.000	0.000		
	Output 2 (MO2) (MAX 500mA depending on external load) IF USED	0	500.000	500.000	0.000	0.000		
	Aux 24VDC (MAX 450mA depending on external load) IF USED	0	450.000	500.000	0.000	0.000		

Installation Checklist

Use the following checklist to ensure that your work is correct and that the commissioning engineer has the necessary information to complete the commissioning of the system.

The commissioning engineer will require this sheet, along with 'Loop Continuity and Insulation Test Results', correctly marked 'as-wired' drawings and completed 'Configuration sheets', before attending site to commission the system.

Stage 1

Description	Installation Engineer Checked	Commissioning Engineer Checked
	LOOP 1	LOOP 1
Loop cable installed correctly, clipped or in containment.		
All loop bases and back boxes installed and terminated.		
All devices have positive core links in place.		
Loop insulation and continuity testing complete, and form filled out.		
As-wired drawing marked up showing cable runs and devices.		
Configuration sheets completed with devices descriptions etc.		
Control Panel back box installed with 230v AC supply live, tested and isolated locally.		

Stage 2

Depending on the terms of your contract, you may also be required to carry out 'Stage 2'.

Description	Installation Engineer Checked	Commissioning Engineer Checked
	LOOP 1	LOOP 1
Devices installed into bases and back boxes.		
Detector dust covers fitted.		
Serial numbers noted on drawings and 'Configuration Sheets'.		

Site Name & Address:	
Installation Company:	
Testing Engineer:	
Signature:	
Date:	

Commissioning Checklist

The following checklist may be used to ensure that all steps are taken. It serves as a reminder only and may need additional items added if required.

Step 1

Description	Commissioning Engineer Checked
	LOOP 1
Low voltage test meter shows 0v and earth continuity, and no inter-core short circuits. (+ve core will only have continuity if link pins fitted instead of devices. LEGACY DEVICES ONLY)	
All devices installed and initialised in sections until entire system is initialised satisfactorily.	
All faults (device, input, output, EOL, battery, etc.) cleared from control panel.	
Correct operation and device poll verified using Sita DIAGNOSTIC.	

Step 2

Data Uploaded to PC.	
Configuration set up on PC.	
Data downloaded to control panel.	
Addressable loop reconfigured.	
System Reset.	
All ancillary inputs and outputs connected and faults cleared.	

Step 3

Correct operation of all input devices tested, ie, detectors, manual call points and inputs.	
Correct operation of all output devices tested, ie, sounders, relays and outputs.	
Correct operation of all programmed actions tested, ie, instant, delays, confirmation alarms, multi-stages.	

Step 4

System Manuals completed, zone chart or zone list displayed.	
End user or responsible person trained and user manual issued.	

Site Name & Address:	
Commissioning Company:	
Commissioning Engineer:	
Signature:	
Date:	

Loop Continuity and Insulation Test Results

After installation of the cable, and termination into all the relevant back-boxes, ensure that the link pins (legacy devices only) are installed as necessary in order to be able to take cable continuity and insulation readings. Make sure that all the cables are dressed smoothly and neatly into their back-boxes in order that they will not be disturbed after the readings are taken.

The commissioning engineer will require these readings, along with correctly marked 'as-wired' drawings and completed configuration sheets, before attending site to commission the system.

CORE	CONTINUITY READING (OHMS)
LE1 +ve to LE2 +ve	
LE1 -ve to LE2 -ve	
LE1 Scrn to LE2 Scrn	

A reading of approximately 1.2 ohm per 100 metres of 1.5 mm² cable is expected and any significant variation from this should be investigated. If the above readings are satisfactorily showing circuit continuity then you may also take the reading below.

CORE	INSULATION READING (OHMS)
+ve to -ve	
+ve to Screen	
-ve to Screen	
Loop Screen to Mains Earth	

No continuity between cores should be seen and a reading of OL should be shown on the test meter. Any significant variation from this should be investigated. If the readings are satisfactory then the loop wiring is largely proven other than for faults such as complete polarity reversal.

Site Name & Address:	
Installation Company:	
Testing Engineer:	
Signature:	
Date:	

FIRE ALARM SYSTEM NOTICE

To Enable the Control Panel Keypad

The user controls are accessed from Access Level 2 (**USER**) which is reached as follows:

Enter your access code, eg 1234, followed by **ENTER**, or insert the **KEY** and turn it clockwise. The **CONTROLS ENABLE** light will switch **ON**, you are now in Access Level 2 (**USER**) and you may proceed to silence and reset the system.

To prevent unauthorised operation the controls should be kept disabled and the code / key kept secure under the control of the responsible person.

To Manually Operate the Fire Alarm Sounders

To sound the alarms press the **SOUND ALARMS** button at Access Level 2 (**USER**) as above.

Following a Detector or Manual Call Point Operation

The **FIRE** LED will illuminate, the fire alarm sounders and the internal panel buzzer will operate as programmed. Take appropriate action as defined by the emergency plan for the premises.

To silence the alarms press the **SILENCE ALARMS** button at Access Level 2 (**USER**) as above, then establish the cause of the alarm and enter the details in the log book.

Reset any Manual Call Points which may have been operated, or if a detector has been operated be sure that the cause of the alarm has been removed, before resetting the system by pressing the **RESET SYSTEM** button at Access Level 2 (**USER**) as above.

Following a Fault Condition

The appropriate fault LEDs will illuminate. The internal panel buzzer will sound. To mute the internal panel buzzer, press the **SILENCE BUZZER** button at Access Level 2 (User) as above. Investigate and rectify the appropriate fault (competent persons).

To Test the Indication LEDs

Select the **Test Display** prompt with the **UP / DOWN** keys, then press **ENTER** at Access Level 2 (User).

To Disable the Control Panel Keypad

When finished with the controls above, press the **ESC** button, or **turn the key off and remove it**. The system will return to Access level 1 (**NORM**)

The controls enabled light will have switched off and the controls will be disabled.

Important Notes

It is a requirement of the **Workplace Regulations** that your Fire Alarm System must be regularly serviced by competent persons.

FIRE ALARM COMPANY: _____
ADDRESS: _____
For service phone: _____ (Working hours) _____ (Out of working hours)

Note

The Fire alarm system installed in this building utilises '**ALARM CONFIRMATION**' technology to help eliminate false alarms.

Please read and understand the following information in order to make the most effective use of the system.

Operation

When the detector within your area activates it will initially only operate the sounders within your own area for a predetermined 'Alarm Confirmation' time.

At the end of the '**ALARM CONFIRMATION**' time the system will check the detector again to see if the activation has cleared. If so then the sounders will silence and no further action need be taken.

If, however, the detector is still activated then the entire system will go into alarm, operating all the sounders on the system.

Action Required

If you think that you may have accidentally set off the fire alarms then check the following:

If the fire alarm sounders within your area only are operating, then check your own area for the cause of the alarm. If this proves to be a false alarm due to dust, cooking fumes, steam, cigarette smoke, etc, then clear the dust/fumes/smoke from the area in order to allow the system to reset itself after a few minutes. If this happens then no further action is required.

If you discover a genuine fire, then follow the buildings fire procedures for evacuation, if the sounders are not sounding, activate the nearest Fire Alarm manual call point on the way out.

Do not attempt to put out the fire unless it is safe to do so.

Further Information

Further information will be located adjacent to the Main Fire Alarm Control Panel, or may be obtained from either the person responsible for building maintenance or from the Fire Alarm Company responsible for maintaining the Fire Alarm System.

Engineers Notes

Engineers Notes

Engineers Notes

Index

32V Power Input	23
Access Level 0 (Normal).....	32
Access Level 1 (User)	33
Access Level 2 (Supervisor).....	34
Access Level 3 (Engineer).....	41
Access Levels	32
Addressable Circuit Wiring	12
Addressable Loop.....	21
Alarm Confirmation Technology	54
Anti-Static Handling Guidelines	6
Auxiliary Power	22
Batteries.....	25
Battery Connections	27
Cable Entry.....	10
Cable Specification.....	12
Codes.....	32
Commissioning.....	56
Control Panel Disassembly.....	9
Control Panel Main PCB.....	15
Control Panel Terminals	16
Diagnostics	48
Earth Faults	65
EMC	6
End User Training	58
Fault Finding	66
Faults	63, 64, 65, 66, 67
Fire Alarm Controls.....	30
Fuses.....	26
Fuses and Protection.....	71
General Assembly	8
General System Schematic	14
Initialisation.....	61
Installation	10
Introduction	6
LED Indication	29
Loop Controls.....	50
Loop Loading	13
Mains Supply.....	25
Monitored Inputs	18
Monitored Outputs	19
Mounting Data.....	11
Mounting the Control Panel	8
Panel Assembly	11
Panel Backplane Layout	16
Peripheral Bus	17
Physical Dimensions	9
Relay Outputs	20
SLAP System	7
System Controls	31
System Design.....	6
Technical Data.....	70
Temperature Probe	27
Topology & Cabling.....	12
USB Port - User.....	4
View Edit Attributes.....	51

Important Points

- Use a **2-core 1.5mm² with screen fire rated cable** as per the specifications in “Cable Specification” and “Network Cable Specification”.
- Connect all the devices in a complete **loop** (returning from the last device to the control panel).
- Make sure that the cable screens are sleeved, connected together and connected to **the relevant connections at the control panel**.
- Leave a copy of the User Instructions by the control panel, and make sure that you have explained its operation carefully to the relevant persons (the user, not the contractors or their agents).
- Do not remove devices or chambers in earlier devices with the loop active – this could cause the system to go into full fire.

If you have any further queries, please contact your supplier for further information

Technical Support

Please contact your distributor for technical support on this product.

Do not call the Fike Safety Technology technical support department unless your distributor has first given their advice and attempted to rectify the issue.

Technical support will not be available if the instruction manual has not been read and understood. Please have this instruction manual available whenever you call for technical support.

 2831
Fike Safety Technology Ltd Unit 31, Springvale Ind. Est. Torfaen, NP44 5BD 20 DoP- 502-0001
EN54-2: 1997 +A1: 2006, EN54-4: 1997 +A1: 2002 +A2:2006 FIKE CIE-A-200 Intended for use in the fire detection and fire alarm Systems in and around buildings