



<http://www.fike.co.uk/resource-downloads/addressable/>

General Description

The Sita Weatherproof Manual Call Point (MCP) allows for user activation of the fire alarm system. Once operated the device latches into the alarm position and requires manually resetting via a special key.

The MCP is an addressable unit that attaches to the loop. Digital communication technology to the control panel is implemented allowing for accurate data transfer at high transmission speeds.

Before Installation

The MCP must be installed in compliance with the control panel installation manual. The installation must also meet the requirements of any local authority.

Spacing

Fike recommends spacing of call points in accordance with any local authority.

Device Installation

All wiring must be installed in compliance with the recommendations laid out by any local authority as well as any special recommendations documented in the control panel installation manual. **The cabling used should be of a 2-core 1.5mm² screened, fire resistant type, with the following characteristics:**

Max Capacitance Core to Screen.....	180pF / m
Max Capacitance Core to Core	100pF / m
Max Inductance	1.0mH / km
Max Resistance Two Core Screened 1.5mm ²	12.1Ω / km

It is to be wired in the form of a screened 2-core loop returning to the control panel. The use of spurs on this system is not permitted.

Fix the wall mounting plate in a suitable position using the holes / slots. Drill out 20mm holes in back box in required positions for cable glands.

Note: Holes must be clean and free of burrs and surface imperfections. This is critical for seal integrity. IP68 cable glands suitable for cable diameter used must be fitted in accordance with manufacturer's instructions to maintain the IP rating of the unit.

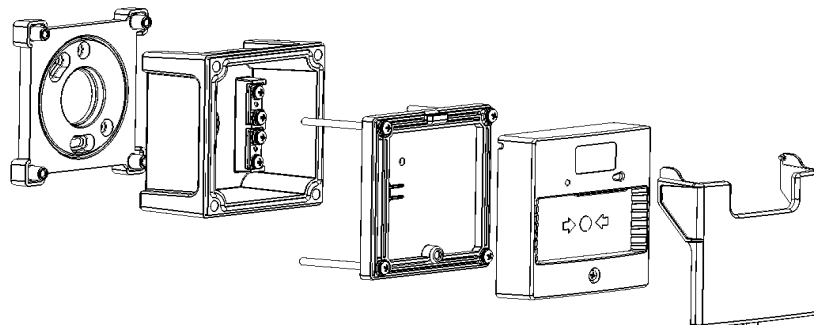

Fit the back box onto the wall mounting plate and terminate cables. Cables may be terminated into the connectors, as shown below. Care should be taken when terminating devices to ensure all cables are correctly sleeved and connections are secure. Improper connections will prevent a system from responding properly in the event of a fire.

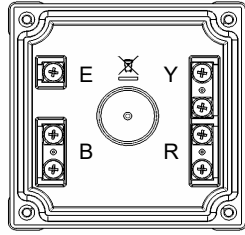
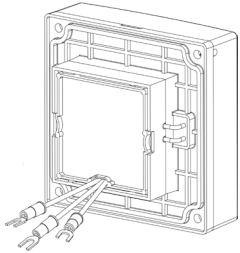

Terminal	Description
R (RED)	Loop +ve IN
Y (YELLOW)	Loop +ve OUT
B (BLUE)	Loop -ve IN & OUT
E	Loop SCREEN IN & OUT

The Loop +ve (positive) IN and the Loop +ve (positive) OUT connections are split within the module. For cable continuity readings at the commissioning stage they must be temporarily removed and connected through. Please remember that all high voltage testing must be carried out before the installation of the electronics, otherwise the electronics will be damaged. Please note that the E terminal should only be connected to the loop screen and NOT the building earth.

Once all testing has been carried out on the cabling and **continuity & insulation** has been proven, the MCP can be connected.

Before installing the MCP remember to note the serial number of the device (located on the rear of the unit) on to your drawings or configuration sheets to enable you to prove its location later. The address allocation for the device is carried out automatically by the control panel whilst in initialisation mode, so addresses do not need to be set manually. See the system Installation and Operating Instructions for further details.

The MCP is installed by pushing the front Interface Plate onto the back box and tightening the four long fixing screws, before locating the upper mounting hook of the MCP front unit onto Interface Plate and then pushing the unit gently home. The single fixing screw may then be tightened.

Reset and Test

The MCP contains a re-settable element, which latches in position when operated and does not need to be replaced. Inserting the key as shown and turning it clockwise until the element clicks back into place will reset the unit. Testing the MCP may be carried out either by pressing the element or by using the key in the same manner as for resetting but without having pressed the element.

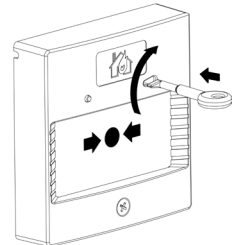

Technical Data

Dimensions:	Width x Height	87mm x 87mm
	Depth: Standard inc base	70mm
Operating Temperature:		-10°C to +50°C
Voltage Range (Loop):		24 to 42V DC
LED Indication:	Activated	0.3s interval
Flammability:		UL94-V2
IP Rating:		IP65
System Compatibility:	Sita200plus V2.00 onwards	
	Duonet and Quadnet V1 onwards	
	CIE-A-200 V1 onwards	

PRODUCT DESCRIPTION			LOOP CURRENT (mA)				
Type	Product Code	Name	Quiescent	Alarm	Low	Medium	High
MCP	403 0007	Sita Manual Call Point Mk3	0.18	2.89	-	-	-

			BATTERY CURRENT (mA)				
Type	Product Code	Name	Quiescent	Alarm	Low	Medium	High
MCP	403 0007	Sita Manual Call Point Mk3	0.18	6.00	-	-	-

			DLU RATING			
Type	Product Code	Name	Alarm	Low	Medium	High
MCP	403 0007	Sita Manual Call Point Mk3	3	-	-	-

Technical Support

Contact your supplier for technical support on this product.

Due to the complexity and inherent importance of a life risk type system training on this equipment is essential, and commissioning should only be carried out by competent persons. Fike cannot guarantee the operation of any equipment unless all documented instructions are complied with, without variation.

Fike's policy is one of continual improvement and the right to change a specification at any time without notice is reserved. Whilst every care has been taken to ensure that the contents of this document are correct at time of publication, Fike shall be under no liability whatsoever in respect of such contents. E&OE

 2831	
Fike Safety Technology Ltd Unit 31, Springvale Ind. Est. Torfaen, NP44 5BD 11 DoP-403-0007	
EN54-11: 2001 +A1: 2005, EN54-17: 2005 Isolator Technical Data: See 26-1112 403-0007 Intended for use in the fire detection and fire alarm Systems in and around buildings	
Essential characteristics	Performance
Nominal activation conditions/Sensitivity, response delay (response time) and performance under fire conditions	Pass
Operational reliability	Pass
Tolerance to supply voltage	Pass
Durability of operational reliability and response delay, Temperature resistance	Pass
Durability of operational reliability, Vibration resistance	Pass
Durability of operational reliability, Humidity resistance	Pass
Durability of operational reliability, Corrosion resistance	Pass
Durability of operational reliability, Electrical stability	Pass
Performance under fire conditions	Pass

