

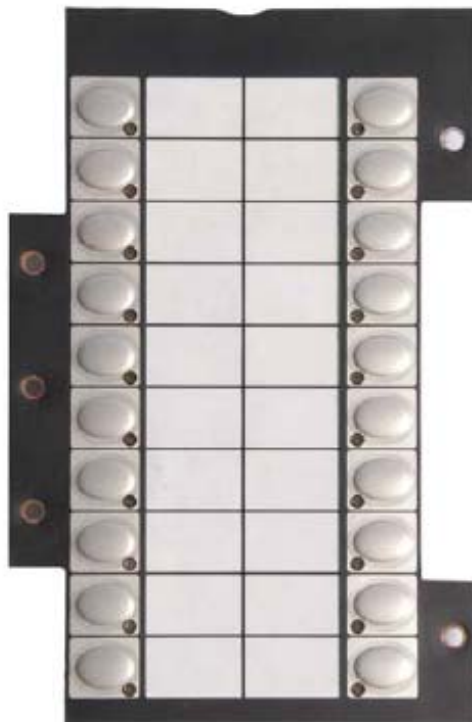

# 10-2659

## Input/Output Control Card



---

**DEVELOPED BY**

Fike  
704 SW 10<sup>th</sup> Street  
P.O. Box 610  
Blue Springs, Missouri 64013 U.S.A.  
Phone: (888) 628-FIKE (3453)  
(816) 229-3405  
Fax: (866) 211-9239

---

**COPYRIGHT NOTICE**

Copyright © 2008. All rights reserved.

Fike copyrights this manual and products it describes. You may not reproduce, transmit, transcribe, or any part of this manual without express, written permission from Fike.

This manual contains proprietary information intended for distribution to authorized persons or companies for the sole purpose of conducting business with Fike. If you distribute any information contained in this manual to unauthorized persons, you have violated all distributor agreements and we may take legal action.

---

**TRADEMARKS**

Fike<sup>®</sup> is a registered trademark of Fike.

---

**QUALITY**

Fike has maintained ISO 9001 certification since 1996. Prior to shipment, we thoroughly test our products and review our documentation to assure the highest quality in all respects.

---

**WARRANTY**

Fike provides a one-year limited manufacturer's warranty on this product. All warranty returns must be returned from an authorized Fike Distributor. Contact Fike's Marketing department for further warranty information.

Fike maintains a repair department that is available to repair and return existing electronic components or exchange/purchase previously repaired inventory component (advance replacement). All returns must be approved prior to return. A Material Return Authorization (MRA) number must be indicated on the box of the item being returned. Contact the appropriate Regional Sales Manager for further information regarding product return procedures.

---

**LIMITATIONS OF LIABILITY**

Installation in accordance with this manual, applicable codes, and the instructions of the Authority Having Jurisdiction is mandatory. Fike can not be held liable for any incidental or consequential damages arising from the loss of property or other damages or losses resulting from the use or misuse of Fike products beyond the cost of repair or replacement of any defective components. Fike reserves the right to make product improvements and change product specifications at any time.

While every precaution has been taken during the preparation of this manual to ensure the accuracy of its content, Fike assumes no responsibility for errors or omissions.

---

## TABLE OF CONTENTS

Section	Title	Page
<b>1.0</b>	<b>About This Manual .....</b>	<b>2</b>
1.1	Document History .....	2
1.2	Product Support.....	2
1.3	Safety Information .....	3
1.4	Terms Used in this Manual.....	3
<b>2.0</b>	<b>Product Description .....</b>	<b>4</b>
2.1	Compatibility .....	4
2.2	Agency Standards and Compliance .....	5
2.3	Related Fire Alarm Standards .....	5
2.4	Related Documentation .....	5
2.5	Specifications .....	5
<b>3.0</b>	<b>Installation.....</b>	<b>6</b>
3.1	Mount the Card.....	6
3.2	Set the Card's Binary Address .....	7
3.3	Pull Field Wiring to Card.....	8
3.4	Connect Field Wiring to Card .....	9
3.5	Power-Up Card.....	9
<b>4.0</b>	<b>Programming .....</b>	<b>10</b>
4.1	Switch Numbering Sequence .....	14
4.2	Control Priorities .....	15
<b>5.0</b>	<b>Operation.....</b>	<b>16</b>
<b>6.0</b>	<b>Testing and Placing Into Service .....</b>	<b>16</b>
<b>7.0</b>	<b>Servicing .....</b>	<b>16</b>

## LIST OF EXHIBITS

Exhibit 1	Operators View.....	4
Exhibit 2	Related Documentation .....	5
Exhibit 3	Mounting Card to Dead-front Panel.....	6
Exhibit 4	Card Addressing.....	7
Exhibit 5	Binary Addressing .....	7
Exhibit 6	Wiring Connections .....	9
Exhibit 7	UL (90.23) Programming Features.....	10
Exhibit 8	UL (90.23) Programming Features – Continued .....	11
Exhibit 9	UL (90.23) Programming Features – Continued .....	12
Exhibit 10	UL (90.23) Programming Features – Continued .....	13
Exhibit 11	Switch & LED Numbering Sequence.....	14



## 1.0 ABOUT THIS MANUAL

This manual is intended to be a complete reference for the installation, operation and service of the Fike Input/Output Control Card. The information contained in this manual shall be used by factory trained service technicians who are authorized to work on this product. This manual also serves as the Operations Manual for the component.

The first-time installer and/or user should thoroughly read and understand the instructions contained within this manual before using this device. These instructions must be followed to avoid damage to the equipment itself or adverse operating conditions caused by improper installation and programming.

### 1.1 DOCUMENT HISTORY

Document Title: Input/Output Control Card, Product Manual

Document Reorder Number: 06-446

Revision	Section	Date	Reason for Change
0	All Sections	10/08	Initial Release
1	Section 3.2	4/09	Clarification of dip-switch functions
2	Section 4.0	05/2010	Added voice evacuation programming options
3	Section 4.1	06/2011	Updated Section 4.0 to include MNS switch functions

### 1.2 PRODUCT SUPPORT

If you have a question or encounter a problem not covered in this manual, you should first try to contact the distributor who installed the Fike system. Fike has a worldwide distribution network. Each distributor sells, installs, and services Fike equipment. Look on the back of the cabinet door, there should be a sticker with an indication of the distributor who installed the system. If you can not locate the distributor, please call Fike Customer Service for locating your nearest distributor, or go to our web-site at [www.fike.com](http://www.fike.com). If you are unable to contact your installing distributor or you simply do not know who installed the system, you can contact Fike Technical Support at (888) 628-3453, Option 2, Monday through Friday, 8:00 am to 4:30 pm CST.

### 1.3 SAFETY INFORMATION

Important safety admonishments are used throughout this manual to warn of possible hazards to persons or equipment.

 <b>Caution</b>
<p>Cautions are used to indicate the presence of a hazard which will or may cause damage to the equipment if safety instructions are not followed or if the hazard is not avoided.</p>

**Note:** Provides information on installation, operation, maintenance, performance or general tips that are important but not hazardous to anything or anyone.

### 1.4 TERMS USED IN THIS MANUAL

**Authority Having Jurisdiction** – The organization, office, or individual responsible for approving equipment, materials, and installation, or a procedure.

**Configure** – Panel set-up to properly recognize and supervise a device as the design requires.

**Dedicated Smoke-Control System** – Smoke-control systems and components that are installed for the sole purpose of providing smoke control, and upon activation these system operate specifically to perform the smoke-control function.

**Fire Alarm Control Unit (FACP)** – A system component that receives inputs from automatic and manual fire alarm devices and might supply power to detection devices and to a transponder(s) or off-premises transmitter(s). The control unit might also operate releasing circuits or solenoids, provide transfer of power to the notification appliances, or transfer of condition to relays or devices connected to the control unit. The fire alarm control unit can be a local fire alarm control unit or a master control unit.

**Fire Fighters’ Smoke-Control Station (FSCS)** – A system that provides graphical monitoring an manual overriding capability over smoke-control systems and equipment at designated location(s) within the building for the use of the fire department.

**Non Dedicated Smoke-Control System** – Smoke-control systems and components that share components with some other system(s), such as the building HVAC system, and upon activation cause the HVAC system to change its mode of operation in order to achieve the smoke-control objectives.

**Power-Limited** – A circuit designation given for wiring purposes. The amount of current flowing through the circuit is limited versus being unlimited, or non-power limited.

**Smoke-Control System** – An engineered system that uses mechanical fans to produce pressure differences across smoke barriers to inhibit smoke movement.

**Zone** – A defined area within the protected premises. A zone can define an area from which a signal can be received, an area to which a signal can be sent, or an area in which a form of control can be executed. This term is used to create the relationship between activation inputs to notification outputs and peripherals.

**RS485** – A data communication standard produced by the Electronics Industry Association (EIA). This standard was developed to allow for reasonable success in transferring data over specified distances and/or data rates.

## 2.0 PRODUCT DESCRIPTION

The 10-2659, Input/Output Control card (See Exhibit 1) provides On-Off control capability over critical system functions, such as smoke control and emergency voice evacuation. The card provides a tabular based display that incorporates twenty (20) momentary touch-pad switches and twenty (20) red/yellow bi-color LEDs to indicate equipment/system status. The card communicates with the associated control panel via the panel's RS485 peripheral bus.

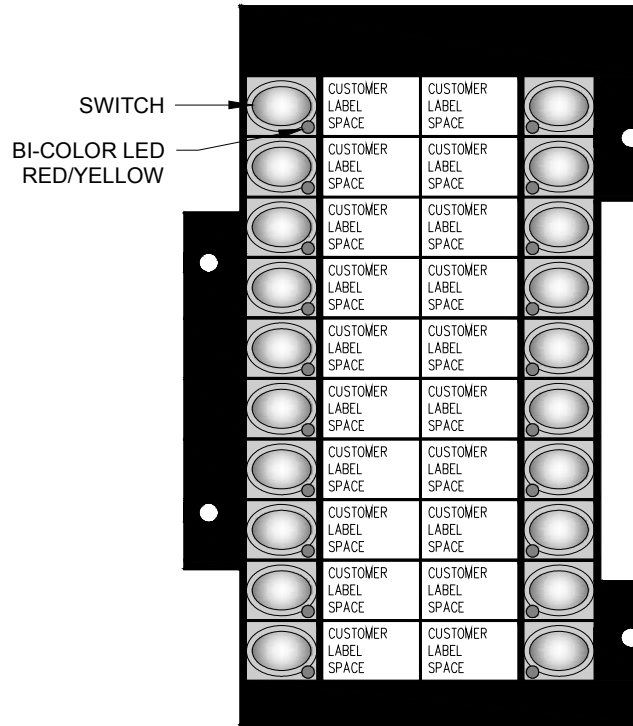

Exhibit 1: Operators View

## 2.1 COMPATIBILITY

The Input/Output card is compatible with the following Fike Intelligent control panels: CyberCat 254 and CyberCat 1016, firmware version 4.XX or higher for smoke control and version 5.XX and higher if used for voice evacuation or mass notification. In order to properly mount the card inside the control panel enclosure, a dead-front enclosure must be used. Refer to the associated control panel manual for system enclosure information.

## 2.2 AGENCY STANDARDS AND COMPLIANCE

This Fire Alarm product complies with the following standards:

- NFPA 70 - NEC, Article 300 Wiring Methods
- NFPA 70 - NEC, Article 760 Fire Protective Signaling Systems
- NFPA 72 - National Fire Alarm Code
- UL 864 – Control Units and Accessories for Fire Alarm Systems
- UL 1711 – Amplifiers for Fire Protective Signaling Systems
- UL 2572 – Mass Notification Systems

## 2.3 RELATED FIRE ALARM STANDARDS

- NFPA 1 - Fire Prevention Code
- NFPA 77 - Static Electricity
- NFPA 92A - Smoke-Control Systems
- NFPA 92B - Smoke Management Systems
- NFPA 101 - Life Safety Code
- Applicable Local and State Building Codes
- Requirements of the Local Authority Having Jurisdiction

## 2.4 RELATED DOCUMENTATION

Further details about the product referenced in this document can be found in the following manuals.

Document Title	Part Number
CyberCat 254/1016 Installation Manual	06-326
CyberCat 254/1016 Operation & Maintenance Manual	06-326-2

**Exhibit 2: Related Documentation**

## 2.5 SPECIFICATIONS

Operating Voltage Range: 15 – 30 VDC<sup>1</sup>

Maximum Current: Alarm = 140 mA (all LEDs on)  
Standby = 51 mA (all LEDs off)

Operating Temperature: 0° to 49° C (32° to 120° F), 93% RH<sup>2</sup>

Terminal blocks accept 14-26 AWG

All Connections are Supervised and Power Limited

RS485 Wiring: 4000 ft. (1219 m) to last device, (96 Ω) maximum, Belden 9841 or equal

Card Dims: 3.75" (9.53 cm) W x 5.75" (14.6 cm) H

<sup>1</sup> Power for the card is provided via a separate power loop from the associated control panel or battery backed 24VDC, regulated, power-limited, power supply listed for Fire Protective Signaling Use.

<sup>2</sup> The useful life of the system's standby batteries and the electronic components may be adversely affected by extreme temperature ranges and humidity. Therefore, it is recommended that this component be installed in an environment with a nominal room temperature of 15-27° C / 60-80° F.

### 3.0 INSTALLATION

The following installation instructions must be strictly adhered to when installing the card to prevent potential damage to the card and the associated control panel.

**⚠ Caution**

The card and associated control panel contains static sensitive components. Always ground yourself with a proper wrist strap before handling any circuits so that static charges are removed from the body. Use anti-static packaging to protect electronic assemblies removed from the unit.

**⚠ Caution**

Never remove or install boards, internal cables or components with power applied. Failure to follow the instructions provided in this section can result in irreparable damage to the system components. This damage may adversely affect the operation of the control unit but its effect may not be readily apparent.

#### 3.1 MOUNT THE CARD

1. Carefully unpack the card and check for shipping damage.
2. Fill out and install custom label in slot provided in card faceplate. Label templates can be downloaded from Fike's Forum web page.
3. Select the mounting location for the card on the dead-front panel and install onto the four threaded standoffs (See Exhibit 3).
4. Secure the card to the dead-front panel using the mounting hardware supplied with the card.

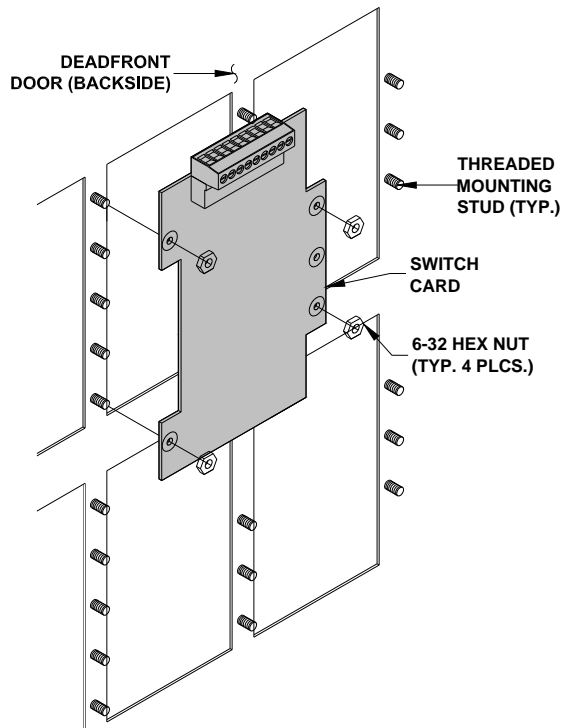
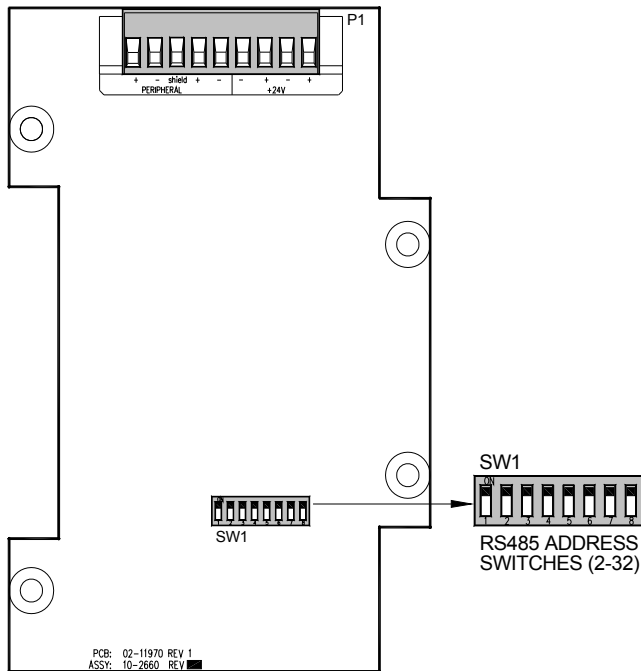

**Exhibit 3: Mounting Card to Dead-front Panel**



### 3.2 SET THE CARD'S BINARY ADDRESS

Each device requires a unique address for identification on the RS485 peripheral buss. DIP switch SW1 (switch 1-6) is used to set the address for the device (See Exhibit 4). A maximum number of 31 devices can be connected to the RS485 peripheral bus circuit. The device addresses do not need to be sequential and can be set to any number between 2 and 32. Note that 00 is not a valid address and 1 is reserved for the control panel. See Exhibit 5 for DIP switch settings for each binary address (ID number).



**Exhibit 4: Card Addressing**

Binary Value	1	2	4	8	16	32
Dip Switch #	1	2	3	4	5	6
Address						
0	NOT VALID					
1	ON	◀ PANEL ONLY				
2		ON				
3	ON	ON				
4				ON		
5	ON			ON		
6		ON		ON		
7	ON	ON		ON		
8					ON	
9	ON				ON	
10			ON		ON	
11	ON	ON			ON	
12				ON	ON	
13	ON			ON	ON	
14			ON	ON	ON	
15	ON	ON	ON	ON		
16						ON
17	ON					ON
18			ON			ON
19	ON	ON				ON
20				ON		ON
21	ON			ON		ON
22			ON	ON		ON
23	ON	ON	ON			ON
24					ON	ON
25	ON				ON	ON
26			ON		ON	ON
27	ON	ON			ON	ON
28				ON	ON	ON
29	ON			ON	ON	ON
30			ON	ON	ON	ON
31	ON	ON	ON	ON	ON	
32						ON

**Exhibit 5: Binary Addressing**

Dip-switch 7 is used to set the peripheral bus communication speed that will be used by the fire-phone card to communicate with the CyberCat panel. The selected communication speed set on the card must match the host control panel settings. In addition, all devices connected to the same peripheral bus must use the same communication speed setting. In the OFF position, the card will communicate at 9600 bps (standard). In the ON position, the card will communicate at 38400 bps (fast).

**⚠ Caution**

Turning dip-switch 8 on will clear the cards configuration.  
Use C-Linx to resend the configuration to the card.

### 3.3 PULL FIELD WIRING TO CARD

Unless otherwise detailed in this manual or in other documents relating to this card, the designer, installation and service technician shall utilize published standards and references such as: NFPA 70 National Electrical Code; NFPA 72 National Fire Alarm Code; and other standards which may be relevant to the Local Authority Having Jurisdiction (AHJ) for field wiring installation requirements.

1. Pull RS485 and 24VDC power wiring to card's terminal block. Leave sufficient wire to make connections at card terminals without straining board components.

#### RS485 Wiring Limitations

The panel's RS485 circuit can drive up to 32 devices including the control panel itself. The number of cards that can be installed on the system is dependent upon the number of devices installed on each fire alarm control panel's RS485 circuit. The RS485 circuit can not be T-Tapped; it must be wired in a continuous fashion. The maximum wire distance from the control panel to the card is 4,000 feet (1,219 m) of Belden 9841 low capacitance cable. For plenum applications, use Belden 82841, 82842, or 89841. Limit the total wire resistance to 96 ohms maximum. Do not run the RS485 (power-limited) cable adjacent to, or in the same conduit as 120 volts AC (non power-limited) circuits, noisy electrical circuits that are powering mechanical bells or horns, audio circuits above 25 volts RMS, or motor control circuits.

#### 24VDC Wiring Limitations

Power for the card is provided via a separate power loop from the associated control panel or battery backed 24VDC, regulated, power-limited, power supply listed for Fire Protective Signaling Use. The card must be accounted for in the control panel power and battery calculations. Utilize the power information provided in Section 2.5 for these calculations. If the control panel is configured to supervise the card, a loss of power will register as a communication failure at the control panel.

**Note:** If card power is supplied from a source other than the control panel, a ground fault condition could occur. To correct this problem, disable (isolate) ground fault detection on the field power supply. Ground fault detection will be performed by the host control panel.

2. Temporarily short conductors at one end and measure the total wire resistance. Compare measured value(s) to the listed circuit limitations for the particular panel that the card is being tied to. If values are within the circuit limitations, proceed to next step.

#### **Caution**

If megger testing of field wiring is required, all field devices MUST be disconnected from the circuit prior to testing. Megger testing could damage electronic components.

### 3.4 CONNECT FIELD WIRING TO CARD

1. Disconnect AC power and batteries from the control panel and wait 60 seconds prior to connecting field wiring. Failure to do so can damage circuits.
2. Disconnect all RS485 connections from the control panel.
3. Connect the RS485 circuit wiring to card's removable terminal block P1 (See Exhibit 6). Land outgoing shield wire to SHLD terminal. Do not land incoming shield wire. Insulate from shorts and grounds.
4. Remove the 100-ohm resistor and connect outgoing RS485 circuit wiring to terminal block P1 (See Exhibit 6). If last device on Class B circuit, leave the resistor in place.
5. Connect the 24VDC wiring to card's removable terminal block P1 (See Exhibit 6).
6. Connect outgoing 24VDC wiring (if applicable) to card's removable terminal block P1 (See Exhibit 6).

**⚠ Caution**

1. Do not over tighten screw terminals. Over tightening may damage threads, resulting in reduced terminal contact pressure and difficulty with screw terminal removal.
2. Do not reverse the 24VDC power and RS485 wiring. Damage to the system will occur.

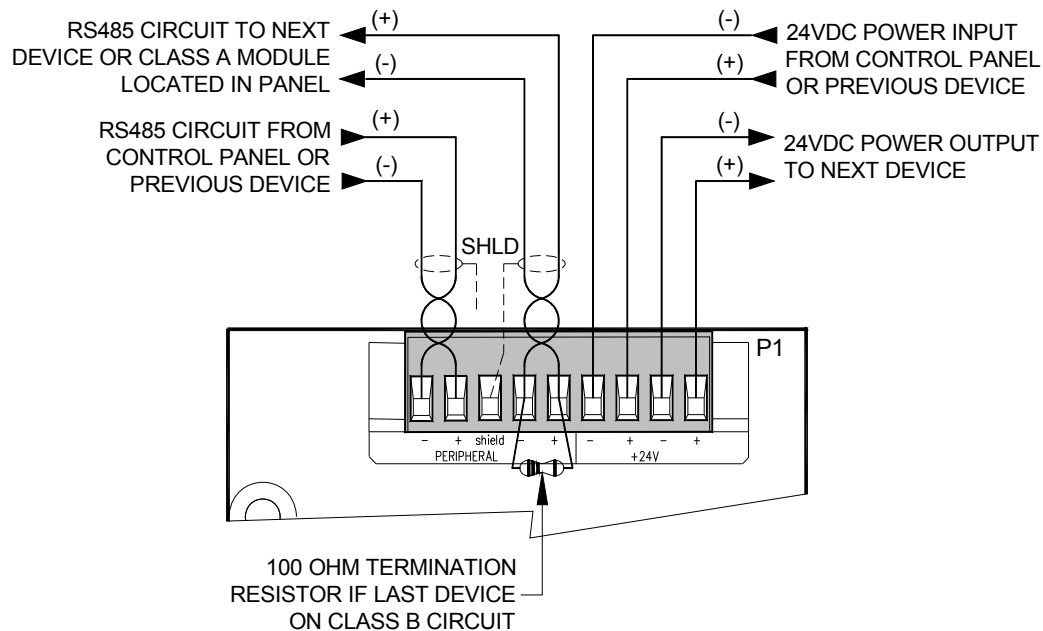

**Exhibit 6: Wiring Connections**

### 3.5 POWER-UP CARD

1. After all boards, cables and components have been properly installed; reapply AC power and batteries (in that order) to the associated control panel or field power supply. Immediately remove power if the panel or card(s) shows signs of abnormal operation.
2. Reconnect all RS485 connections to the control panel.



### 4.0 PROGRAMMING

Each Input/Output card must be programmed through the associated control panel using a lap top computer and Fike's C-Linx software. Refer to Fike document 06-448, "C-Linx Software manual" for programming instructions. Programming cable 10-1874A is used to download the configuration to the card via the control panel's P3 configuration port.

The following tables identify the configurable features of the input/output card that can be changed by using the panel's programming software C-Linx. The table also identifies features that are available, but are not permitted to be used per the CyberCat™ system's UL listing.

**Exhibit 7: UL (90.23) Programming Features**

Circuit or Component	Program Feature or Option	Permitted in UL 864? (Y/N)	Possible Settings (Defaults shown bold)	Settings permitted in UL 864	Notes	
Switch Card 20-Zone	Peripheral Address	Y	2 - 32			
	<i>Switch Configuration (1 – 20)</i>					
	Function	Y	<b>No Function Assigned</b> / Panel Reset / Panel Silence / Panel Acknowledge / LED Test / Panel Walktest Mode 1 / Panel Walktest Mode 2 / Panel Drill / Zone Process Toggle / Zone Disable Toggle / Smoke Control / Alarm Silence / Supervisory Silence / Trouble Silence / Voice Alert / Voice Evacuate / Voice Page / Voice Record Page / Voice Page to Alert / Voice Page to EVAC / Voice Play Message ID / MNS Silence / MNS Page / MNS Record Page / MNS Play Message ID			
	Zone	Y	<b>0</b> – 254		1	
	Settings		Y	Relay Action / Zone Assignments / Zones and Message ID		2
			Y	<b>Latching</b> / Non-Latching	Latching	5
Priority	Y	<b>0</b> – 254 ( <b>Default 1</b> )			3	
Timeout	Y	<b>0</b> – 250 (min.)			4,5	

Notes:

1. This field is active for Zone Process and Zone Disable Toggle functions only. Selects zone number to be associated with switch activation.
2. This field is active only when the switch function is set for Smoke Control, Voice Alert, Voice Evacuate, Voice Page, Voice Record Page, Voice Play Message ID, MNS Page, MNS Record Page, or MNS Play Message ID.
3. Sets the operational priority of the switch with 0 = None; 1 = Highest and 254 = Lowest.
4. Sets a timeout for the switch operation.
5. This is only allowed for MNS switch functions.

Exhibit 8: UL (90.23) Programming Features – Continued

Circuit or Component	Program Feature or Option	Permitted in UL 864? (Y/N)	Possible Settings (Defaults shown bold)	Settings permitted in UL 864	Notes
Switch Card 20-Zone	<i>Relay Action Settings (Selection table active for Smoke Control only)</i>				
	Relay Action	Y	<b>None</b> / On / Auto / Off		1,2
	Action Start	Y	<b>Action starts with confirmation address OR delay timer</b> / Action starts with confirmation address AND delay timer		
	Confirmation Address	Y	Panel: <b>0</b> - 128		
			Loop: <b>0</b> - 4		
			Address: <b>0</b> - 254		
	Relay Address	Y	Panel: <b>0</b> - 128		
			Loop: <b>0</b> - 4		
			Address: <b>0</b> - 254		
	Delay Timer	Y	<b>0</b> – 255 seconds		
	Delay (timer) Start	Y	<b>Delay timer starts immediately</b> / Delay timer starts after confirmation address activates		
	<i>Zone Assignments (Selection table active for Voice Functions only)</i>				
	Select Zones	Y	1 – 254		
	Selection Options	Y	Select / Clear		
		Y	All Zones / Even Zones / Odd Zones		
		Y	Between: 1 – 254		
		Y	And: 1 – <b>254</b>		
		Y	Any Zone (check box)		
		Y	Select All / Clear All / Invert All		
	<i>Zones and Message ID (Selection table active for Play Message ID Functions only)</i>				
	Select Zones	Y	1 – 254		
	Selection Options	Y	Select / Clear		
		Y	All Zones / Even Zones / Odd Zones		
		Y	Between: 1 – 254		
		Y	And: 1 – <b>254</b>		
		Y	Any Zone (check box)		
		Y	Select All / Clear All / Invert All		
	Message 1	Y	<b>0</b> - 16		3
	Message 2	Y	<b>0</b> - 16		3

Notes:

1. On and Off overrides up to 25 addressable relays on the panel's SLCs.
2. Auto returns up to 25 addressable relays back to automatic configured state.
3. Assigns the message ID that will be played when the switch is pressed. Maximum two messages.



Exhibit 9: UL (90.23) Programming Features – Continued

Circuit or Component	Program Feature or Option	Permitted in UL 864? (Y/N)	Possible Settings (Defaults shown bold)	Settings permitted in UL 864	Notes
Switch Card 20-Zone	<i>LED Configuration (1 – 40)</i>				
	LED Function	Y	<b>No Function Assigned</b> / On – Device Activation / On – Device Trouble / On – Device Active or Trb. / On – Device PreAlarm / On – Device Active or PreAlm / On – Zone Process / On – Zone Trouble / On – Zone Supervisory / On – Zone Abort / On – Zone Disable / On – Zone PreAlarm / On – Zone Alarm / On – Zone Predischarge / On – Zone Release / One Zone Test Alarm / Zone – Zone Action / On – Panel Silence / On – Panel Drill / On - Panel Walktest / On – Panel Comm OK / On – Panel Power OK / On – Panel Buzzer Active / On – Any Network Device Active / On – Any Network Device Trouble / On – Any Network Device PreAlm / On – All Network Device Active / Off – Any Network Device Active / Off – All Network Device Active / On – Any LED Active / On – All LED Active / Off – Any LED Active / Off – All LED Active / On - Alarm Silence Inhibit / On – Device Active or Prealm(Stdy) / On – Battery Trouble / On – Voice Alert / On – Voice Evacuate / On – Voice Page / On – Voice Record Page / On – Voice Page to Alert / On – Voice Page to EVAC / On – Voice Play Message ID / MNS Silence / MNS Page / MNS Record Page / MNS Play Message ID		1
	Timer	Y	<b>0</b> – 255 seconds		
	Assignment	Y	<b>Device</b> / Zone / Net Device / LED (corresponds with LED function)		
	Switches	Y	1 - 20		

Notes:

- Switches assigned to panel operation events affect the local panel only, unless other network panels are configured to respond to network events.

Exhibit 10: UL (90.23) Programming Features – Continued

Circuit or Component	Program Feature or Option	Permitted in UL 864? (Y/N)	Possible Settings (Defaults shown bold)	Settings permitted in UL 864	Notes
Switch Card 20-Zone	<i>Assignment by Device</i>				
	Select Devices	Y	1 – 254		
	Selection Options	Y	<b>Select / Clear</b>		
		Y	<b>All Addresses / Even Addresses / Odd Addresses / All Photo Sensors / All Photo/Heat Sensors / All Photo/Duct Sensors / All Ion Sensors / All Heat Sensors / All Monitor Modules / All Dual Monitor Modules / All Mini Monitor Modules / All Pull Station Modules / All Conventional Zone / All Control Modules / All Relay Modules / All Releasing Modules</b>		
		Y	On Loop: <b>1 – 4</b>		
		Y	Between: <b>1 – 254</b>		
		Y	And: <b>1 – 254</b>		
	Y	Select All / Clear All / Invert All			
	<i>Assignment by Zone</i>				
	Select Zones	Y	1 – 254		
	Selection Options	Y	Select / Clear		
		Y	All Zones / Even Zones / Odd Zones		
		Y	Between: <b>1 – 254</b>		
		Y	And: <b>1 – 254</b>		
		Y	Any Zone (check box)		
	Y	Select All / Clear All / Invert All			
	<i>Assignment by Network Device</i>				
	Select Devices	Y	1 – 254		
	Select Options	Y	<b>All Addresses / Even Addresses / Odd Addresses / All Photo Sensors / All Photo/Heat Sensors / All Photo/Duct Sensors / All Ion Sensors / All Heat Sensors / All Monitor Modules / All Dual Monitor Modules / All Mini Monitor Modules / All Pull Station Modules / All Conventional Zone / All Control Modules / All Relay Modules / All Releasing Modules</b>		
		Y	On Panel: <b>1 – 128</b>		
		Y	On Loop: <b>1 – 4</b>		
		Y	Between: <b>1 – 254</b>		
		Y	And: <b>1 – 254</b>		
	Y	Select All / Clear All / Invert All			
	<i>Assignment by LED</i>				
	Select LED Assignments	Y	1 - 40		

### 4.1 SWITCH NUMBERING SEQUENCE

Input/Output card LEDs and switches (1 – 20) “track” or follow those system functions or points they are programmed to annunciate; they do not latch. Exhibit 11 shows the numbering sequence for the LEDs and switches.

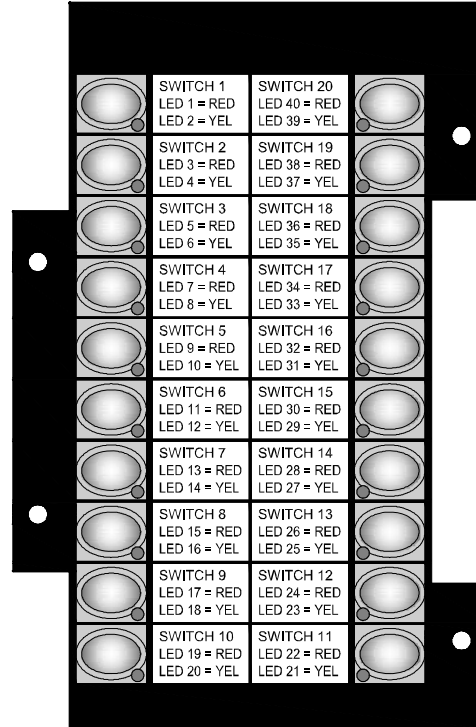

Exhibit 11: Switch & LED Numbering Sequence



## 4.2 CONTROL PRIORITIES

Fike's voice system utilizes control priority levels to resolve which switch has operational priority over another switch that is programmed for the same operation. A switch card with a lower priority setting cannot override a switch card with a higher priority. Switch cards with the same priority setting can override another switch card with the same priority setting or a lower priority setting. Each card must be assigned a priority level from 0 to 254 using the panel's configuration software (C-Linx). 1 is the highest priority and 254 is the lowest priority. A setting of 0 disables the cards control priorities and must be used on all system where priority schemes are not utilized.

### **Example 1:**

A switch in the fire command center (FCC) and local operating console (LOC) have both been programmed for EVAC Zone 1. The switch in the FCC enclosure has been assigned a priority level of 1, while the switch in the LOC has been assigned a priority level of 2. Pressing the switch in the FCC enclosure will cause Zone 1 to enter into the EVAC state. Both the switch in the FCC enclosure and the LOC will indicate that the EVAC state is active by turning on the corresponding switch LED. Since the switch in the LOC has a lower priority than the switch in the FCC enclosure, pressing the Zone 1 EVAC switch in the LOC to cancel the EVAC will have no effect.

### **Example 2:**

A switch in the fire command center (FCC) and local operating console (LOC) have both been programmed for Page Zone 1. Both switches have been assigned a priority level of 1. Pressing the switch in the FCC will cause Zone 1 to enter into the PAGE state. Both the switch in the FCC and LOC will indicate that the PAGE state is active by turning on the corresponding switch LED. The Remote Page Active LED in the LOC will activate and the Local Page Active LED in the FCC will activate. Since the switch in the LOC has a the same priority level as the switch in the FCC, pressing the Zone 1 PAGE switch in the LOC will cause the active Zone 1 PAGE to cancel.

## 5.0 OPERATION

The Input/Output control card allows you to manually initiate programmed system functions simply by pressing the corresponding switch. Once pressed, the switch will initiate any one of the programmed functions as identified in Exhibit 8 under Switch Configuration.

The operation of the card's LEDs varies depending on the custom configuration as follows:

### Smoke Control Confirmation:

- Flash upon initiation of one of the smoke control override switches until confirmation of desired smoke control override function is achieved via activation of monitor module(s) connected to smoke control equipment status relay contacts.
- Flash if time limit has expired for smoke control equipment to achieve their desired state (trouble operation).
- Steady On when in normal operation.

### Normal System Input Functions:

- Flash upon initiation of one of the switches until confirmation of requested function is received from CyberCat™ panel.
- Flash if time limit has expired for control panel/modules to achieve their desired state (trouble operation).
- Steady On when in normal operation.

## 6.0 TESTING AND PLACING INTO SERVICE

To ensure proper system operation, this product must be tested in accordance with the requirements of NFPA 72 after programming operation or change in site-specific software. Reacceptance testing is required after any change, addition or deletion of system components, or after any modification, repair or adjustment to system hardware or wiring.

All components, circuits, system operations, or software functions known to be affected by a change must be 100% tested. In addition, to ensure that other operations are not inadvertently affected, at least 10% of initiating devices that are not directly affected by the change, up to a maximum of 50 devices, must also be tested and proper system operation verified.

## 7.0 SERVICING

There are no serviceable components on this card.



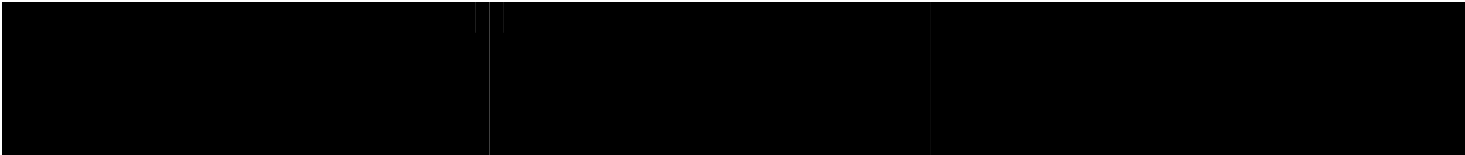

704 SW 10<sup>th</sup> Street  
P.O. Box 610  
Blue Springs, Missouri 64013

Tel: (816) 229-3405  
Fax: (816) 229-0314  
[www.fike.com](http://www.fike.com)