

General Description

The Loop Monitored Output module provides an interface between ancillary devices and the loop. It can be configured as an output to control external devices or systems that require a 24VDC trigger that also monitors the cable condition between the module and device. Digital communication technology to the control panel is implemented, allowing for accurate data transfer at high transmission speeds. This device includes a loop short-circuit isolator..



Before Installation

The monitored output module must be installed in compliance with the control panel installation manual. The installation must also meet the requirements of any local authority.

Positioning

The module should be mounted securely and care should be taken to ensure the device is accessible for future maintenance.

Device Installation

All wiring must be installed in compliance with the recommendations laid out by BS5839 Pt1 as well as any special recommendations documented in the control panel installation manual. **The cabling used should be of a 2-core 1.5mm² screened, fire resistant type, and is to be wired in the form of a screened 2-core loop returning to the control panel. The use of spurs on this system is not permitted.** Care should be taken when terminating devices to ensure all cables are correctly sleeved and connections are secure. Improper connections will prevent a system from responding properly in the event of a fire.

The Loop IN +Ve (positive) and the Loop OUT +Ve (positive) connections are split within the module, for cable continuity readings at the commissioning stage they must be temporarily removed and connected through. Please remember that all high voltage testing must be carried out before the installation of the electronics, otherwise the electronics will be damaged. Please also note that the SCRIN terminal should only be connected to the loop screen and NOT the building earth.

Once all testing has been carried out on the cabling and **continuity & insulation** has been proven, the Monitored Output Module can be connected.

Connection Schematic

Before installing the module remember to note the serial number of the device (located on the rear of the unit) on to your drawings or configuration sheets to enable you to prove its location later. The address allocation for the device is carried out automatically by the control panel whilst in initialisation mode, so addresses do not need to be set manually

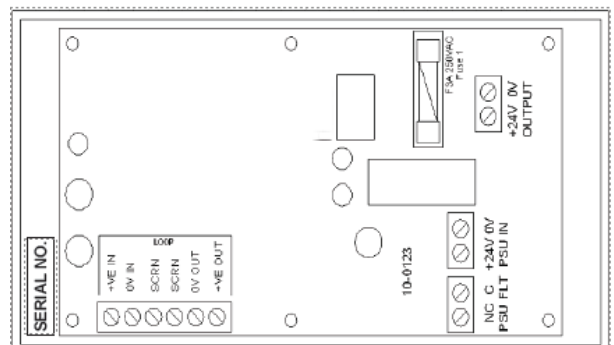
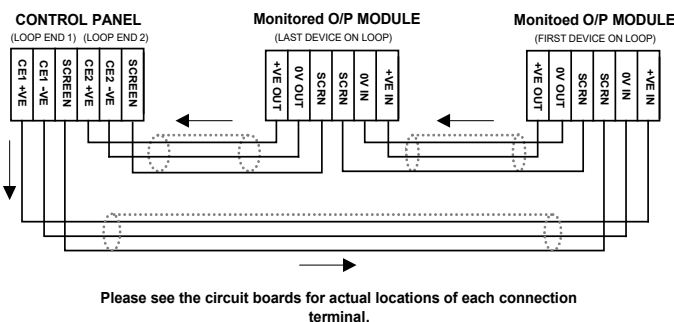

Device Settings

The Monitored Output settings are configured using the relevant panel software configuration package.

The Monitored Output Module may be connected to the addressable circuit in order to provide a monitored voltage output from the fire alarm system. The physical connections are shown below.

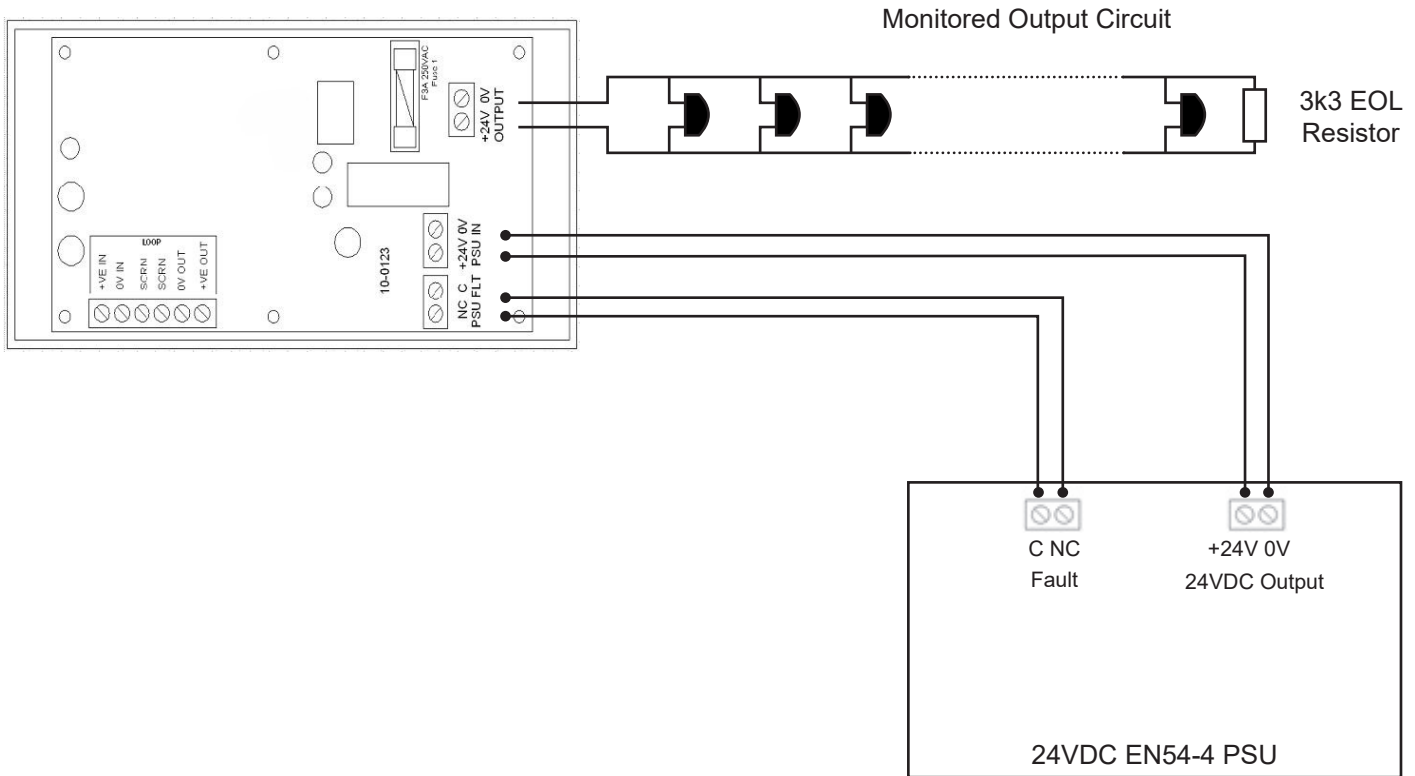

Notes: This module monitors the output circuit only in the quiescent state using a reverse voltage. Any devices connected to the monitored output circuit MUST be polarised and protected from operation if voltage is applied in the reverse polarity. This can normally be achieved by the addition of blocking diodes.

The PSU FLT terminals are monitored for fault during both the quiescent and active states. The terminals require a normally closed contact from the fault output of a suitable EN54-4 approved 24VDC power supply.

FIKE SAFETY TECHNOLOGY LTD.

Unit 31 Springvale Industrial Estate | Cwmbran NP44 5BD, United Kingdom | +44 (0) 1633 865 558

Technical Data

Dimensions: Overall 146mm x 87mm x 41mm
 Back box 146mm x 87mm x 32mm

Operating temperature: -10°C to +50°C.

Voltage Range: 32 to 42v DC

PSU In Voltage: 24 to 32v DC

LED Indication: Output Activated LED on

Contact Rating: Output Max load 2.5A

Fuses: Fuse 1 3A Anti surge 20mm (eg. Bussman S505-3.15A)

System Compatibility: Sita200plus V2.30 onwards
 Duonet and Quadnet V1 onwards
 CIE-A-200 V1 onwards
 CIE-A-400 V1 onwards

PRODUCT DESCRIPTION			LOOP CURRENT (mA)				
Type	Product Code	Name	Quiescent	Active	Low	Medium	High
O/P	803-0022	Monitored O/P Module	0.2	9.63	-	-	-

			BATTERY CURRENT (mA)				
Type	Product Code	Name	Quiescent	Active	Low	Medium	High
O/P	803-0022	Monitored O/P Module	0.2	20.06	-	-	-

			DLU RATING			
Type	Product Code	Name	Active	Low	Medium	High
O/P	803-0022	Monitored O/P Module	10.5	-	-	-

IMPORTANT - PLEASE READ BEFORE INSTALLATION

Sita Loop Monitored O/P Module Output Relay Contacts

The Sita Loop Monitored O/P Module VAD contacts are sent out from the factory set to their normal quiescent operating state.

Since this O/P is a latched relay, it is possible due to rough handling during transit, for the VAD output contacts in the Sita Loop Monitored O/P Module to become knocked from their factory set state into their active state.

The VAD output is labelled +24V & 0V OUTPUT.

If the VAD output contacts are in the active state they must be reset to the normal quiescent state.

This is done by connecting the Sita Loop Monitored O/P Module to a loop and programming it as an output using the OSP Program. The Sita Loop Monitored O/P Module must then be cycled by creating an alarm and then silencing and resetting at the panel. This will put the output contacts back into the normal quiescent operating state.

Technical Support

Contact your supplier for technical support on this product.

Due to the complexity and inherent importance of a life risk type system training on this equipment is essential, and commissioning should only be carried out by competent persons. Fike cannot guarantee the operation of any equipment unless all documented instructions are complied with, without variation.

Fike's policy is one of continual improvement and the right to change a specification at any time without notice is reserved. Whilst every care has been taken to ensure that the contents of this document are correct at time of publication, Fike shall be under no liability whatsoever in respect of such contents. E&OE

Fike Safety Technology Ltd Unit 31, Springvale Ind. Est. Torfaen, NP44 5BD 11 DoP-803-0022
EN54-17: 2005, EN54-18: 2005 Isolator Technical Data: See 26-1112
803-0022 Intended for use in the fire detection and fire alarm Systems in and around buildings