

### General Description

The Loop I/O module provides an interface between ancillary devices and the loop. It can be configured as an input allowing for reporting from other systems / devices or as an output to control external systems. Digital communication technology to the control panel is implemented, allowing for accurate data transfer at high transmission speeds.



### Before Installation

The I/O module must be installed in compliance with the control panel installation manual. The installation must also meet the requirements of any local authority.

### Positioning

The module should be mounted securely and care should be taken to ensure the device is accessible for future maintenance.

### Device Installation

All wiring must be installed in compliance with the recommendations laid out by any local authority as well as any special recommendations documented in the control panel installation manual. **The cabling used should be of a 2-core 1.5mm<sup>2</sup> screened, fire resistant type, and is to be wired in the form of a screened 2-core loop returning to the control panel. The use of spurs on this system is not permitted.** Care should be taken when terminating devices to ensure all cables are correctly sleeved and connections are secure. Improper connections will prevent a system from responding properly in the event of a fire.

The Loop IN +VE (positive) and the Loop OUT +VE (positive) connections are split within the module, for cable continuity readings at the commissioning stage they must be temporarily removed and connected through. Please remember that all high voltage testing must be carried out before the installation of the electronics, otherwise the electronics will be damaged. Please also note that the SCRIN terminal should only be connected to the loop screen and NOT the building earth.

Once all testing has been carried out on the cabling and **continuity & insulation** has been proven, the I/O Unit can be connected.

### Connection Schematic

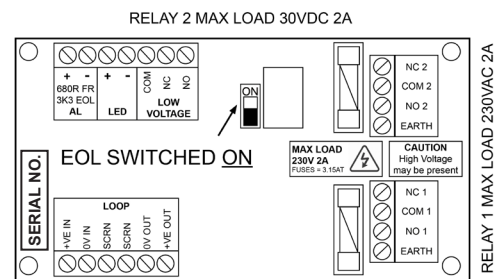
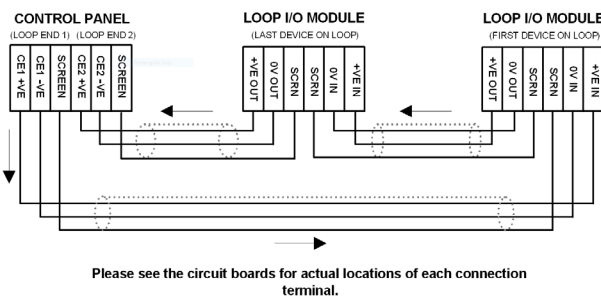

Before installing the module remember to note the serial number of the device (located on the rear of the unit) on to your drawings or configuration sheets to enable you to prove its location later. The address allocation for the device is carried out automatically by the control panel whilst in initialisation mode, so addresses do not need to be set manually.

## Device Settings

The I/O settings are configured using the relevant panel software configuration package.

The Loop I/O Module may be connected to the addressable circuit in order to provide an input to, or an output from the fire alarm system. The unit may be configured as an input or an output, not both. The physical connections are shown below.

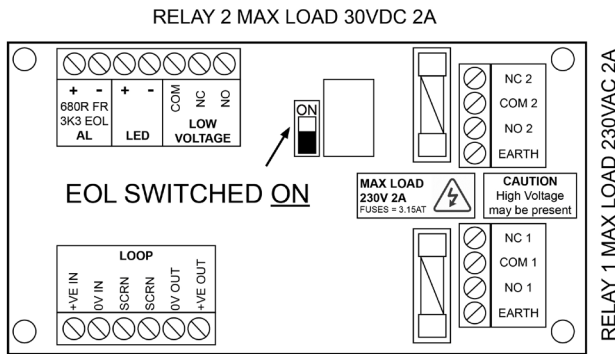

### Output Relay without Fault Monitoring

For use as a simple 'change-over' relay output, connect as shown on the left, **remembering to set the EOL (end of line) switch to ON.**

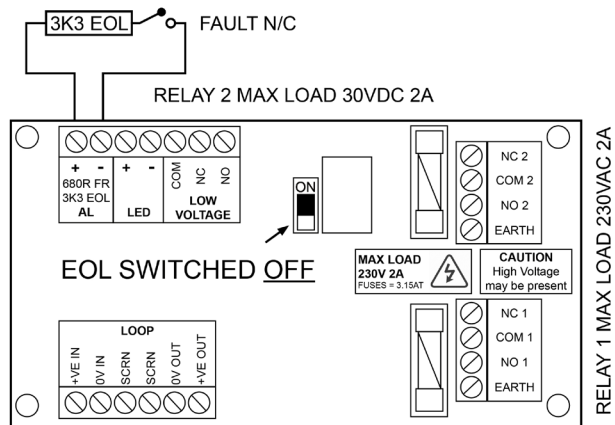

### Output Relay with Fault Monitoring

For use as a 'change-over' relay output with fault monitoring, connect as shown on the right, **remembering to set the EOL (end of line) switch to OFF**, and to use a volt free fault contact to break the EOL circuit in order to generate a fault condition.

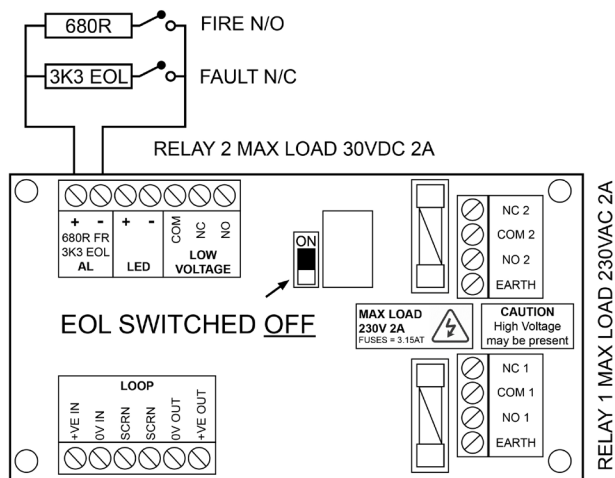

### Input with Fault Monitoring

For use as a fault monitored input, connect as shown on the right, **remembering to set the EOL (end of line) switch to OFF.**

Use a volt free fire contact to make the circuit in order to generate a fire condition and a volt free fault contact to break the circuit in order to generate a fault condition.

## Technical Data

<b>Dimensions:</b>	Overall	146mm x 87mm x 41mm
	Back box	146mm x 87mm x 32mm
<b>Operating temperature:</b>		-10°C to +50°C.
<b>Voltage Range:</b>		24 to 42v DC
<b>LED Indication:</b>	Output Activated	LED on
<b>Contact Rating:</b>	Relay 1	Max load 230V AC 2A (DPCO)
	Relay 2	Max load 30V DC 2A (SPCO)
<b>Fuses:</b>	Fuse 1, Fuse 2	3.15A Antisurge 20mm Ceramic (eg. Bussman S505-3.15A)

**Important note:** All 230V AC mains voltage connections should switch both Live and Neutral. The installation of these connections should only be carried out by suitably qualified persons whilst the mains supply is fully isolated.

**System Compatibility:** Duonet and Quadnet V1 onwards.  
CIE-A-200 V1 onwards.

PRODUCT DESCRIPTION			LOOP CURRENT (mA)				
Type	Product Code	Name	Quiescent	Active	Low	Medium	High
I/O	803 0006	Loop I/O Module	0.2	9.63	-	-	-

			BATTERY CURRENT (mA)				
Type	Product Code	Name	Quiescent	Active	Low	Medium	High
I/O	803 0006	Loop I/O Module	0.42	20.06	-	-	-

			DLU RATING			
Type	Product Code	Name	Active	Low	Medium	High
I/O	803 0006	Loop I/O Module	10.5	-	-	-

## IMPORTANT - PLEASE READ BEFORE INSTALLATION

### Sita Loop I/O Module Output Relay Contacts

Sita Loop I/O Module output relay contacts are sent out from the factory set to their normal operating state.

Since these are latched relays, it is possible due to rough handling during transit, for the relay output contacts in the Sita Loop I/O Module to become knocked from their factory set state into their active state.

Depending on the use to which the I/O unit is to be put (i.e. if it is critical that the first time power up is in the normal operating state), it may be necessary to check the output contact position before connecting the output device.

There are three sets of output contacts: the low voltage contacts are labelled NO, NC, COM and the 230V contacts are labelled NC1, COM1, NO1 for one set and NC2, COM2, NO2 for the other set.

Before connecting the Sita Loop I/O Module to a loop, check for the correct output contact state using a continuity tester.

The correct normal operating state is as follows:

1. There should be continuity between COM and NC on all three sets of output contacts.
2. There should be no continuity (open circuit) between COM and NO on all three sets of output contacts.

If any of the output contacts are the reverse of the above, they are in the active state and must be reset to the normal state before connecting any equipment to the output contacts.

This is done by connecting the Sita Loop I/O Module to a loop and programming it as an output using the OSP Program. The Sita Loop I/O Module must then be cycled by creating an alarm and then silencing and resetting at the panel. This will put the output contacts back into the normal operating state.

### Technical Support

**Contact your supplier for technical support on this product.**

Due to the complexity and inherent importance of a life risk type system training on this equipment is essential, and commissioning should only be carried out by competent persons. Fike cannot guarantee the operation of any equipment unless all documented instructions are complied with, without variation.

Fike's policy is one of continual improvement and the right to change a specification at any time without notice is reserved. Whilst every care has been taken to ensure that the contents of this document are correct at time of publication, Fike shall be under no liability whatsoever in respect of such contents. Errors and omissions excepted, (E&OE)

	
<b>Fike Safety Technology Ltd</b> <b>Unit 31, Springvale Ind. Est.</b> <b>Torfaen, NP44 5BD</b>	
<b>DoP-803-0006</b>	
<b>EN54-17: 2005, EN54-18: 2005</b> <b>Isolator Technical Data: See 26-1112</b>	
<b>803-0006</b> <b>Intended for use in the fire detection and fire alarm</b> <b>Systems in and around buildings</b>	
Essential characteristics	Performance
Nominal activation conditions/Sensitivity, Response delay (response time) and performance under fire conditions	Pass
Operational reliability	Pass
Tolerance to supply voltage	Pass
Durability of operational reliability and response delay, Temperature resistance	Pass
Durability of operational reliability, Vibration resistance	Pass
Durability of operational reliability, Humidity resistance	Pass
Durability of operational reliability, Corrosion resistance	Pass
Durability of operational reliability, Electrical stability	Pass
Performance under fire conditions	Pass
Response delay (response time)	Pass