

General Description

The Sita Multipoint ASD is a plug-in type smoke detector that utilises a photo-electric sensing chamber to make a measurement corresponding to smoke density. The device also incorporates a thermistor sensing circuit to allow for accurate heat measurement. These elements allow the device to be configured to a smoke, heat or combined setting. Digital communication technology to the control panel is implemented allowing for accurate data transfer at high transmission speeds.



Before Installation

The detector must be installed in compliance with the control panel installation manual. The installation must also meet the requirements of any local authority.

Spacing

Fike recommends spacing detectors in accordance with any local authority. Due to the effects of IR and possible magnetic interference, detectors should not be fitted any closer than 500mm (preferably 1000mm) to a light fitting or any other source of IR or EMI. In addition to this recommendation, the device should be mounted so that the indication LED is facing towards the light source.

Detector Installation

All wiring must be installed in compliance with the recommendations laid out by any local authority as well as any special recommendations documented in the control panel installation manual. The cabling used should be of a 2-core 1.5mm² screened, fire resistant type with the following characteristics:

- Max Capacitance Core to Screen 180pF / m
- Max Capacitance Core to Core 100pF / m
- Max Inductance 1.0mH / km
- Max Resistance Two Core Screened 1.5mm² 12.1Ω / km

It is to be wired in the form of a screened 2-core loop returning to the control panel. The use of spurs on this system is not permitted. Cables may be terminated into the connectors mounted in the base, as shown below. Care should be taken when terminating devices to ensure all cables are correctly sleeved and connections are secure. Improper connections will prevent a system from responding properly in the event of a fire.

The Loop +ve (positive) IN and the Loop +ve (positive) OUT connections are automatically joined together (short circuit) by a spring arm between terminals 2 and 3 until the detector is installed. This allows for cable continuity readings at the commissioning stage.

Terminal	Description
1	LOOP 0V * Loop -ve IN & OUT
2	LOOP +IN Loop +ve IN
3	LOOP +OUT Loop +ve OUT
4	AUX +VE * Auxiliary +ve if used
5	AUX -VE Auxiliary -ve if used
SCRN	Cable Screen

Please remember that all high voltage testing must be carried out before the installation of the electronics, otherwise the electronics will be damaged. Please also note that the SCR terminal should only be connected to the loop screen and NOT the building earth.

Once all testing has been carried out on the cabling and continuity & insulation has been proven, the Sita Multipoint ASD detector head may be fitted. Before installing the head remember to note the serial number of the device (located on the rear of the detection head) onto your drawings or configuration sheets to enable you to prove its location later. The address allocation for the device is carried out automatically by the control panel whilst in initialisation mode, so addresses do not need to be set manually.

***For Remote LED use Terminals
1(0v) & 3(+ve)**

To install the detection head, locate the plastic guides into the base and gently twist clockwise until the unit locks in place.

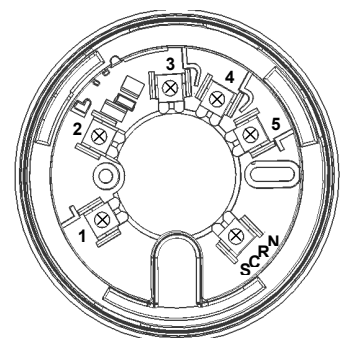

Tamper Resistance and Head Removal

The Sita Multipoint ASD detector incorporates a tamper resistant locking mechanism that prevents its removal from the base without the use of a special tool. To remove the device, the tool should be attached over the detector and turned anti-clockwise allowing the detector to be removed from the base (no other tool should be used as it may damage the device and locking mechanism preventing the device from calibrating).

A head removal keyring is also available

HEAD REMOVAL TOOL (25-0046-201) HEAD REMOVAL KEYRING (23-0244-510)

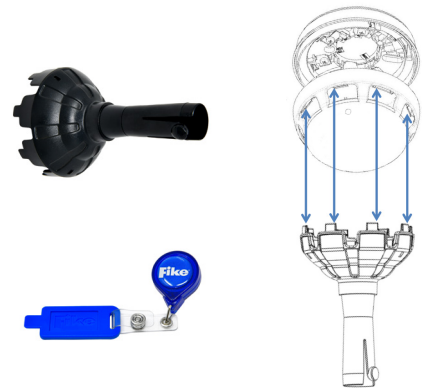

Remote LED (not available if Auxiliary Input / Output used)

The remote LED terminals may be used to connect a separate external LED unit (Fike part no. 600-0092) to the detector that will activate only when the device to which it is connected enters an alarm condition. The Fike LED unit incorporates the necessary 10k Ohm current limiting resistor. No other components or equipment may be connected to the detector remote LED terminals. Connection of other components or equipment may damage the detector. This feature cannot be used at the same time as an auxiliary input or output.



REMOTE INDICATOR
IF REQUIRED

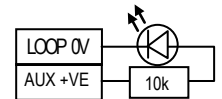

Auxiliary Input / Output (not available if Remote LED used)

Where Input/Output functionality is required other than at the control panel, it is recommended that a separate Sita Loop I/O Module is fitted to the addressable loop as a dedicated I/O module. Where this is not possible, a limited auxiliary I/O facility is available from the detector via the auxiliary I/O terminals with the addition of a separate Sita Multipoint Boxed Auxiliary I/O Module. Either an input or an output may be controlled through this additional I/O interface module. Please see the relevant panel programming manual for details of the options available for different modes of operation. Note that an input or output may only be connected to the detector via the Sita Multipoint Boxed Auxiliary I/O Module. Input/Output components or equipment must not be connected directly to the detector auxiliary terminals otherwise damage may occur. This feature cannot be used at the same time as a remote LED. Note also that sound pattern SP4 or SP6 should not be used if the detector I/O facility is used.

Beacon Operation

If the unit includes a Visual Indication Beacon, this consists of a number of high output LEDs mounted beneath a diffusing lens at the lowest part of the detector. The beacon will start to operate when the device receives a command to activate its sounder, even if the sound pattern is set to SP0 - Sounder off. If only the beacon is required to operate (without the sounder), SP0 must be selected via the configuration software.

Head Contamination Warning

Warning of head contamination is in two stages. Firstly in the form of a 'Quiescent optical level high or low' event recorded into the event log and fault or warnings list (depending on the control panel being used), and secondly in the form of a 'Smoke sensor failed; signal high event, recorded into the event log and fault list.

If the smoke detection mode is set to SM0 (off) the head contamination may still be monitored at the detector depending on the smoke mode, but not by the panel. If contamination is present then the result will be an LED flash every five seconds at the detector, but the panel will show no fault. Thus, if a device is being re-programmed to re-enable a smoke detection mode which has been turned off, check the LED status of the device first and ensure that a clean optical chamber is present. If this is not checked and the smoke detection mode is re-enabled, the device could signal a fire alarm when re-configured.

Replacing Contaminated Optical Chambers

The optical chamber within the detector is not user serviceable. When an optical chamber becomes contaminated we recommend replacing the detector. Cleaning an old chamber is not possible with this device as it is a sealed unit. It is essential that the location of the contaminated device is verified using the device address indicated in the event log. Do not rely on the device text alone as it is not uncommon for descriptions to be conflicting or outdated. Once the device has been identified, see "Replacing Sita Multipoint ASD detector".

Replacing Sita Multipoint ASD Detectors

If a detector requires replacement after the system has been programmed and tested then proceed as follows: Stop the loop at the control panel before replacing the detector with a new one, noting its serial number onto the configuration sheets. Initialise the loop from the control panel and re-configure the loop devices using the Re-config command. This will send the programmed settings from the control panel to the loop devices. The panel should then be reset and the device tested for all programmed modes of operation.

Device Settings

The detection and sounder modes may be configured using the relevant panel software configuration package (OSP).

	Type	Description
Detection Off:	OFF	No smoke or heat detection
Smoke Modes:	SM1	Highly thermally enhanced optical detector. Used where ionization detectors are normally fitted, especially where there are high ceilings or a risk of free burning fires.
	SM2	Thermally enhanced optical. General purpose smoke detector, to be used where optical detectors are normally fitted, where there is a risk of a smouldering fire and for escape routes.
	SM3 *	Thermally enhanced optical with smoke pulse rejection. Used where optical detectors are normally used in positions exposed to brief concentrations of water vapour or smoke e.g from a bathroom, kettle, etc.
Heat Modes:	HM1	Rate of rise to 58°C. Used where a standard rate of rise detector would be fitted, e.g. not kitchens.
	HM2	Low fixed temperature 58°C. Used where a standard fixed temperature heat detector would normally be fitted, e.g. suitable for domestic kitchens, etc.
	HM3 *	High fixed temperature 90°C. Used where a high fixed temperature heat detector would normally be fitted, e.g. suitable for boiler rooms, commercial kitchens, etc.
Sound Patterns:	SP0	Sounder off
	SP1	Single tone, 970 Hz continually
	SP2	Pulsed UK alert signal, 970 Hz 1s on, 1s off
	SP3	Dual tone UK evacuate signal, 970 Hz 0.25s, 800 Hz 0.25s
	SP4	Sweep up, 800 Hz to 970 Hz over 1s
	SP5	Slow whoop up, 500 to 1200 Hz over 3s, 0.5s off
	SP6	Sweep down, 1200 Hz to 500 Hz over 1s
	SP7	Dual tone French warble, 550 Hz 0.1s, 440 Hz 400ms
	NOTE	Sound Patterns SP4 and SP6 are not compatible with the detector I/O facility.
Sound Volume:	L/M/H	Low, medium and high settings are available.

See the Engineering & Commissioning Manual for your control panel (Duonet, Quadnet, and CIE-A-200/400) for further details of how to program the above and all other device settings.
 * This mode is not LPCB certified.

Testing

Due to the fact that the smoke detection modes are all 'thermally enhanced', it may be noticeable that on test the devices respond more slowly than may be expected. This is perfectly normal and is due to the fact that during a smoke test we have no heat present to cause the sensitivity to be enhanced. Please note that some makes of heat detector test equipment will not operate with these devices due to the position of the thermistor.

Technical Data

Dimensions:	Diameter	107mm
	Depth: Standard inc base	67mm
	Depth: Beacon inc base	75mm
Operating temperature:		-10°C to +50°C
Voltage Range (Loop):		24 to 42V DC
Beacon Operation:	Flash Duration	5ms
	Flash Interval	1s
	IP Rating:	IP21C
LED Indication:	Normal	50ms on / 20s interval
	Fault	0.1ms on / 5s interval
	Fire	50ms on / 400ms interval
System Compatibility:	MPS -	Duonet, Quadnet & CIE-A-200/400 V1 onwards
	MP -	Duonet, Quadnet & CIE-A-200/400 V1 onwards

PRODUCT DESCRIPTION			VOLUME LEVEL (dBA) @ 1m anechoic (Dual Tone)		
Type	Product Code	Name	Low	Medium	High
MP	205 0003	ASD Mk3	-	-	-
MPS	205 0001	ASD Mk3 with Sounder	65+	80	85
MPS	205 0012	ASD Mk3 with Sounder/Strobe	65+	80	85

			LOOP CURRENT (mA)				
Type	Product Code	Name	Quiescent	SP0 - Off	Low	Medium	High
MP	205 0003	ASD Mk3	0.12	0.96	-	-	-
MPS	205 0001	ASD Mk3 with Sounder	0.12	0.99	1.48	4.03	5.84
MPS	205 0012	ASD Mk3 with Sounder/Strobe	0.12	3.99	4.48	7.03	8.84

			BATTERY CURRENT (mA)				
Type	Product Code	Name	Quiescent	SP0 - Off	Low	Medium	High
MP	205 0003	ASD Mk3	0.24	2.00	-	-	-
MPS	205 0001	ASD Mk3 with Sounder	0.24	2.07	3.09	8.39	12.17
MPS	205 0012	ASD Mk3 with Sounder/Strobe	0.24	8.32	9.34	14.64	18.42

			DLU RATING			
Type	Product Code	Name	SP0 - Off	Low	Medium	High
MP	205 0003	ASD Mk3	1	-	-	-
MPS	205 0001	ASD Mk3 with Sounder	1	1.5	4.5	6
MPS	205 0012	ASD Mk3 with Sounder/Strobe	4.5	5	8	10

N.B. All specified volume and current readings, unless otherwise stated are taken using sound pattern SP3. Quadnet/Duonet OSP versions prior to v2.04 do not include all the above DLUs.

Technical Support

Contact your supplier for technical support on this product.

Due to the complexity and inherent importance of a life risk type system training on this equipment is essential, and commissioning should only be carried out by competent persons. Fike cannot guarantee the operation of any equipment unless all documented instructions are complied with, without variation.

Fike's policy is one of continual improvement and the right to change a specification at any time without notice is reserved. Whilst every care has been taken to ensure that the contents of this document are correct at time of publication, Fike shall be under no liability whatsoever in respect of such contents. E&OE

 2831 0832	
Fike Safety Technology Ltd Unit 31, Springvale Ind. Est. Torfaen, NP44 5BD DoP-205-0001, DoP-205-0003, DoP-205-0012 EN54-3: 2006 + 2019, EN54-5:2017+A1:2018 EN54-7:2018, EN54-17: 2005, EN54-18: 2005 Sounder Technical Data: See 26-0747 Isolator Technical Data: See 26-1112 205-0001, 205-0003, 205-0012 Intended for use in the fire detection and fire alarm Systems in and around buildings	
Essential characteristics	Performance
Nominal activation conditions/Sensitivity, response delay (response time) and performance under fire conditions	Pass
Operational reliability	Pass
Tolerance to supply voltage	Pass
Durability of operational reliability and response delay, Temperature resistance	Pass
Durability of operational reliability, Vibration resistance	Pass
Durability of operational reliability, Humidity resistance	Pass
Durability of operational reliability, Corrosion resistance	Pass
Durability of operational reliability, Electrical stability	Pass
Performance under fire conditions	Pass
Durability of operational reliability, Resistance to ingress	Pass
Response delay (response time)	Pass