

IMPULSE ACTUATED HRD SUPPRESSOR AND SRD CHEMICAL ISOLATOR



HRD Suppressor



SRD Isolator

Features

- Actuator assembly is driven by a linear actuator that is globally free of shipping restrictions
- High Rate Discharge (HRD) suppressors disperse agent rapidly limiting deflagrations to safe pressures protecting personnel and equipment
- Standard Rate Discharge (SRD) isolators disperse agent both rapidly and sustained to establish a chemical barrier which prevents flame propagation through interconnected pipelines
- Actuator assembly has a 10 year service life reducing total cost of ownership
- Field refurbishable
- Pressure gauge standard
- Optional features include mechanical lockout, ball valve lockout, and low pressure switch

General

The patented HRD Suppressor is specifically designed to reduce the time required to inject and disperse the agent, suppressing combustible dust deflagrations before they generate destructive pressure. Impulse HRD suppressors are available in five sizes ranging from 2.5 to 30 liter. See Ordering Information.

The SRD Isolator is available in a 9L size and is used for chemical explosion isolation. Chemical isolation is often used in conjunction with explosion suppression and explosion venting applications to protect interconnected vessels.

Specifications

Approvals	NFPA 69 compliant ^{1,2}
Operating Temperature	-30°F to 140°F (-34°C to 60°C)
Materials of Construction	Pressure Vessel: High grade carbon steel with white baked urethane enamel
	Initiator/Actuator Assemblies: SST
	Pressure Gauge: SST
Finish	All exposed surfaces: White baked urethane enamel paint
Optional Low Pressure Switch	Supervisory input contact (can be wired NO or NC)
	Set Pressure: SRD = 400 psig HRD = 700 psig
	Electrical Connection: ½" NPT Male
	Pressure Connection: Inlet ¼" NPT Female

¹ HRD containers comply with ASME Boiler and Pressure Vessel Code.

² SRD containers are offered as either compliant with DOT regulations or ASME Boiler and Pressure Vessel Code.

This document is only intended to be a guideline and is not applicable to all situations. Information is subject to Fike's full disclaimer at <http://www.fike.com/disclaimer>.

Ordering Information

Standard Container Sizes
2.5 Liter Impulse HRD assembly (ASME)
5 Liter Impulse HRD assembly (ASME)
10 Liter Impulse HRD assembly (ASME)
20 Liter Impulse HRD assembly (ASME)
30 Liter Impulse HRD assembly (ASME)
9 Liter Impulse SRD assembly (DOT)
9 Liter Impulse SRD assembly (ASME) (All ASME containers meet KGS and ROC requirements)

Container Retrofit Kits	
Part Number	Description
E70-092*	4" Impulse HRD
E70-085*	1" Impulse SRD

* Retrofit of existing installations are subject to Fike EP Applications review of sizing calculations and container verification via inspection tool performed by a Fike trained service technician.

Post-activation Refurbishment Kits	
Part Number	Description
E85-056	4" Impulse HRD, spreader nozzle and no nozzle
E85-057	4" Impulse HRD, hygienic no nozzle
E85-058	4" Impulse HRD, telescopic nozzle
E85-059	4" Impulse HRD, hygienic telescopic nozzle
E85-060	1" Impulse SRD

Suppressant Agents

Fike offers a variety of environmentally safe suppressant agents to meet your specific application. Agents include Sodium Bicarbonate (available in standard or food grade), Monoammonium Phosphate, and a water-based agent.

Spreader Nozzles

The HRD and SRD can be used with all of Fike's standard and telescopic spreader nozzles, except the Extended Duration (XD) nozzle. The spreader nozzles are designed to provide the widest possible dispersion of the suppressant agent. Refer to the compatible spreader nozzle data sheets for specific information.

Dimensions

The overall dimensions of each container is provided in the following table. All container specifications are subject to change without notice.

Type	Size (l)	Dimensions in (cm)				Mtg. Flange	Empty Weight lbs. (kg)
		A	B	C	D		
HRD ¹	2.5	12.06 (30.6)	2.94 (7.5)	7.62 (19.4)	13.65 (34.7)	4" ANSI 300	67 (30.4)
HRD ¹	5	16.07 (40.8)	3.31 (8.4)	10.62 (26.9)	13.90 (35.3)		95 (43.1)
HRD ¹	10	25.82 (65.6)	3.31 (8.4)	10.62 (26.9)	13.90 (35.3)		118 (53.5)
HRD ¹	20	30.58 (77.7)	5.38 (13.7)	12.69 (32.2)	13.90 (35.3)		206 (93.4)
HRD ¹	30	38.83 (98.6)	5.38 (13.7)	12.69 (32.2)	13.90 (35.3)		220 (99.8)
SRD ¹	9	23.98 (60.9)	7.50 (19.0)	NA	NA		NA
SRD ²	9	24.24 (61.6)	7.50 (19.0)	NA	NA	NA	35 (15.9)

¹ ASME design code. ² DOT design code.

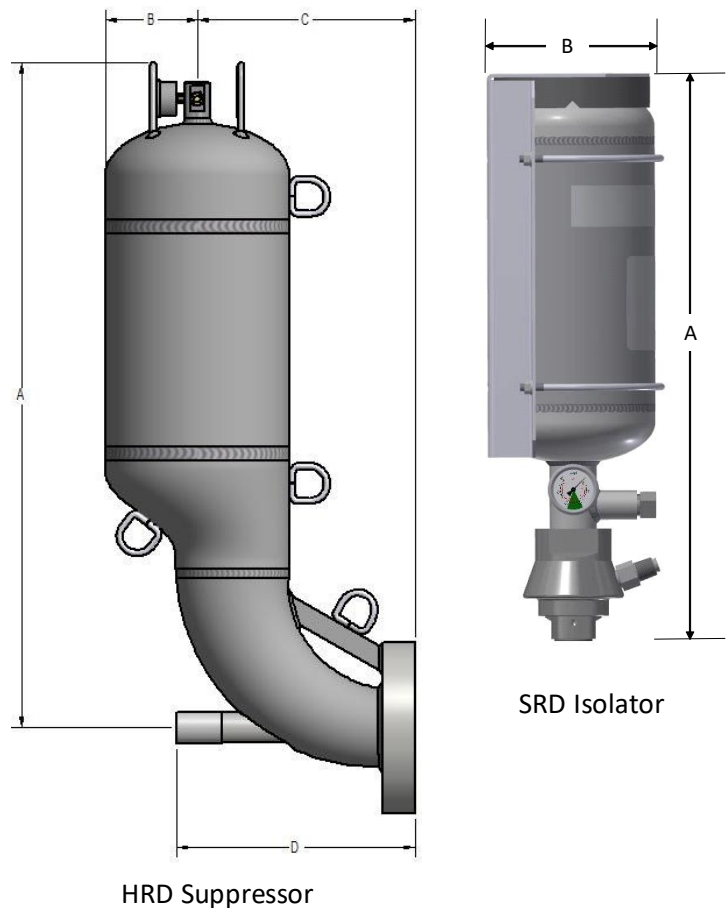

This document is only intended to be a guideline and is not applicable to all situations.

Information is subject to Fike's full disclaimer at <http://www.fike.com/disclaimer>.