

IR TOOL

DESCRIPTION

The IR Tool (P/N 55-051) is a hand-held remote control that is designed to communicate with all System Sensor Eclipse devices (Fike CyberCat® and Cheetah® Xi devices) via infrared signals. The remote control will give the user the ability to communicate with devices through any selected device on the loop. The remote can read device information such as type, loop, address and sensitivity along with write loop, address, branch and service date, and initiate walk test/device test. The remote features a 16-character liquid crystal display and a 17-button keypad.



SPECIFICATIONS

Dimensions:	1.3"H x 2.2"W x 7.7"L (33mm H x 56mm W x 196mm L)
Communication Range:	30 ft. (9.1 m) 24 ft (7.3m) with dust cover on device
Battery Life (2 AA, batteries not included):	168 hrs (typical usage)
Storage Temperature Range:	22 to 140°F (-30 to 60°C)
Operating Temperature Range:	32 to 122°F (0 to 50°C)

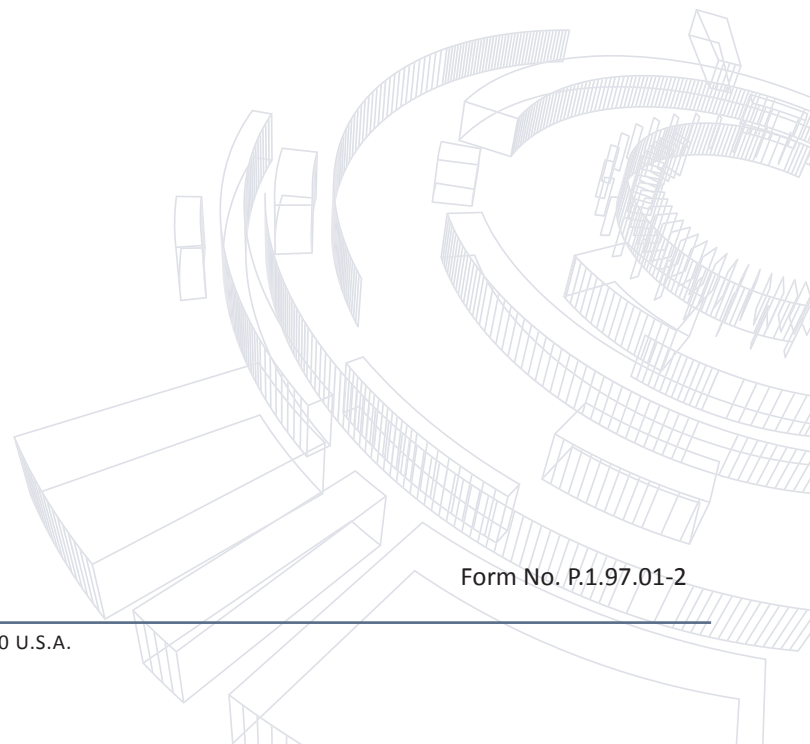

Form No. P.1.97.01-2

(This page is left blank intentionally)