

PNEUMATIC SIREN

DESCRIPTION

The pressure operated siren (P/N C02-1230) is used to warn personnel of a system discharge. The siren is operated with the carbon dioxide pressure from the system. The siren is connected to the system piping using the 1/2" NPT connection located at the base of the siren. The pressure spins the turbine and sounds the siren from the beginning of the discharge throughout most of the discharge time.

The siren operates at a minimum decibel level of 90 dB at 10ft. (3m). The siren requires a CO2 flow rate of 6 lbs. /min. (1.9 kg/min.) The siren is constructed of brass and finished with red, corrosive resistant paint.

SPECIFICATIONS

Part Number: C02-1230
 Materials: Pneumatic Siren - Brass
 Mounting Plate - Stainless Steel

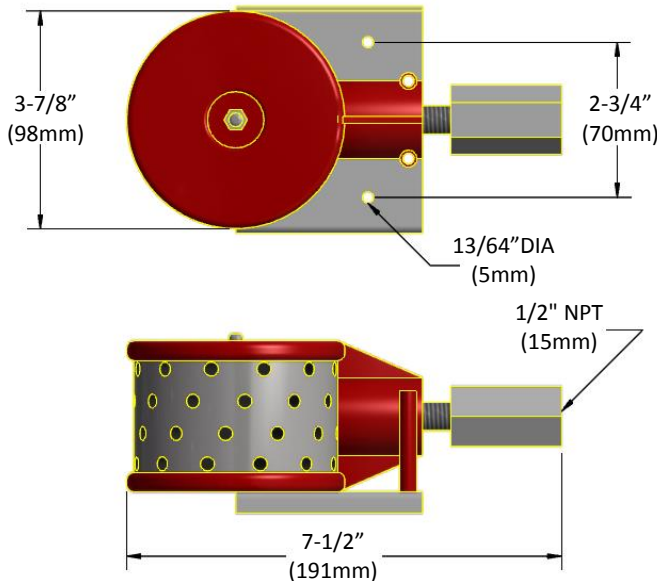

APPROVALS:

- UL Listed
- ULC Listed
- FM Approved
- USCG Approved