

## WET ALARM CHECK VALVE (WAC)

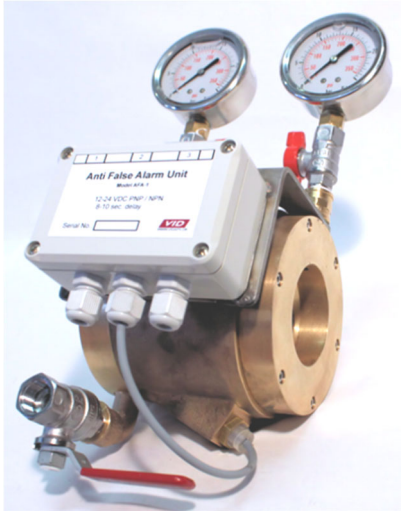

### Description

The Wet Alarm Check (WAC) valve is a clapper and wafer style check alarm valve designed to be installed in wet pipe water mist systems downstream from the system pump where the valve is fitted between two flanges. The valve is capable of detecting the small water flows which are common in the DuraQuench™ system. The valve has built in inlet and outlet pressure gauges, a drain valve, an inductive alarm sensor and Anti-False Alarm (AFA) unit. The valve's inductive alarm sensor provides an electrical means to detect water flow through the valve without direct contact with moving parts.

The AFA is connected to the WAC valve and monitors the inductive alarm sensor for indication of water flow. The AFA provides a factory set time delay of 8 – 10 seconds, which reduces the risk of false alarms coming from pressure shocks in the pipe system. The unit provides a relay contact that provides a means to send a signal to the alarm panel for activation of a water flow alarm bell. The unit requires 12 – 24 VDC power for operation.

The WAC valve contains sensitive components (electrical and mechanical) and should be handled with care.

## Specifications

Alarm Valve	
Fike Part Number	02-14875-2, 1 1/2" (DN 40) 02-14875-1, 2" (DN 50)
Materials	Bronze & Brass
Working pressure	232 psi (16 bar) maximum 7.25 psi (0.5 bar) minimum
Minimum detection flow rate	9.24 gal/min, ±0.8 gal/min (35 l/min, ± 3 l/min)
Anti False Alarm Unit	
Inductive Switch Type	PNP/NPN
Power Supply	12 – 24 VDC
False Alarm Signal	8 sec. max.
Alarm Delay	10 sec.
Cable Diameter	5 – 7 mm
Box Rating	IP 64
Box Material	Plastic
General	
Working Temp	40°F – 130°F (5°C – 55°C)
Weight	02-14875-2 (10.4 lbs. / 4.7 kg)
	02-14875-1 (14 lbs. / 6.35 kg)
Approvals	FM (HC1 occupancies)

This document is only intended to be a guideline and is not applicable to all situations. Information is subject to Fike's full disclaimer at <http://www.fike.com/disclaimer>.

## Spare Parts

Fike Part Number	Description
02-15259-1	Gasket Kit for 2" (DN 50) valve
02-15259-2	Gasket Kit for 1 ½" (DN 40) valve
02-15259-3	Inductive Alarm Kit
02-15259-4	Spindle and Hangers for 2" (DN 50) valve
02-15259-5	Spindle and Hangers for 1 ½" (DN 40) valve
02-15259-6	Anti-False Alarm Unit

## Dimensions

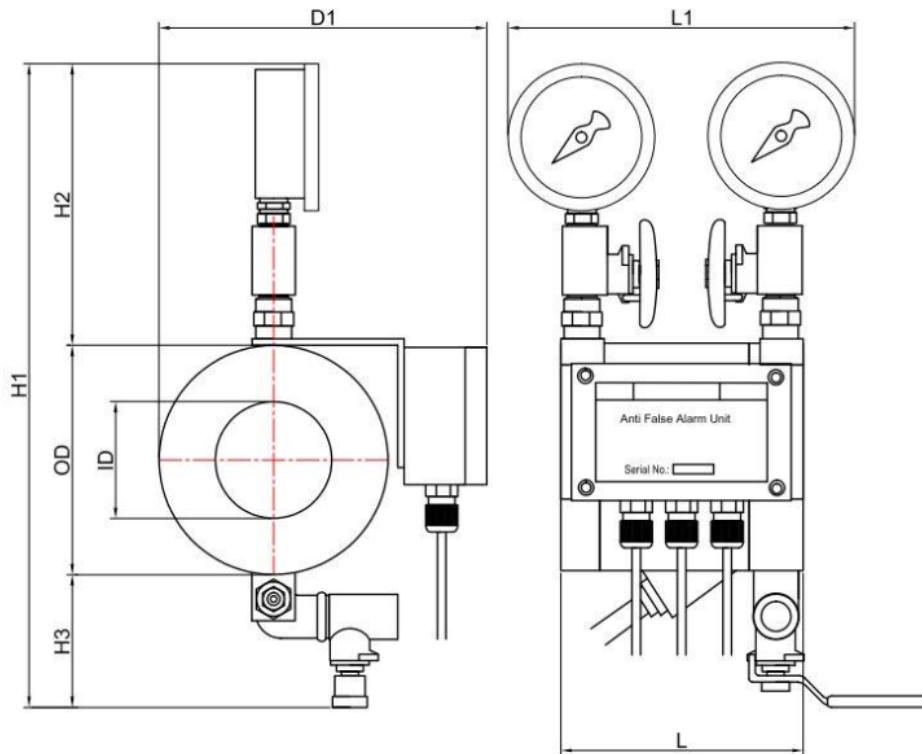

	02-14875-2, 1-1/2" (DN40)	02-14875-1, 2" (DN50)
L	4.13 in. (105 mm)	4.41 in. (112 mm)
L1	6.00 in. (153 mm)	6.30 in. (160 mm)
H1	11.34 in. (288 mm)	11.81 in. (300 mm)
H2	5.12 in. (130 mm)	5.12 in. (130 mm)
H3	2.52 in. (64 mm)	2.52 in. (64 mm)
OD	3.70 in. (94 mm)	4.17 in. (106 mm)
ID	1.65 in. (42 mm)	2.13 in. (54 mm)
D1	5.75 in. (146 mm)	6.30 in. (160 mm)

This document is only intended to be a guideline and is not applicable to all situations. Information is subject to Fike's full disclaimer at <http://www.fike.com/disclaimer>.