

TEST CONNECTION (POTTER ROEMER)



Description

The Test Connection is used to permit the flow of water from the pump skid assembly, to test the flow capacity and operation of the fire pump during initial acceptance and annual testing. The test connection provides a connection point for a fire hose that can be used to direct the water stream generated during the test to a safe discharge location.

A test connection shall be provided on all water mist systems, as outlined in NFPA 750.

Specifications

Fike Part Number	02-14942
Material	Polished Brass
Inlet	2-1/2" female NPT
Outlet	Male hose thread snoot with cap and chain
Lettering	8" plate "HYDRANT"
Listing / Approval	FM Approved

Dimensions

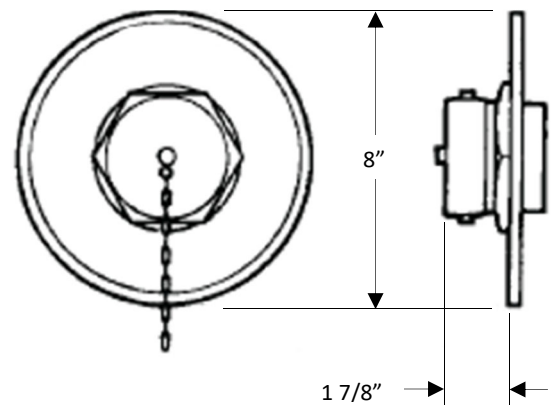

This document is only intended to be a guideline and is not applicable to all situations. Information is subject to Fike's full disclaimer at <http://www.fike.com/disclaimer>.