

DOUBLE DISC SERIES – POLY-SD, SRL AND SCRD-V

DESCRIPTION

The complete double disc (DD) holder assembly consists of two bursting discs installed in a holder made of three separate components – the base, mid-flange and hold down (see figure 1). The GI configuration allows for ease of installation and maintenance, with preassembly of the unit on a workbench before simple insertion between companion flanges (see figure 2). A pretorqueable execution allows for removal, inspection and eventual re-installation after successful inspection and acceptance.

Standard configurations use Poly-SD, SRL and SCRD-V series bursting discs, for other bursting disc types consult factory. As with all bursting discs there is a wide choice of materials for optimum resistance to corrosive processes.

FEATURES AND BENEFITS

- Effective compensation of backpressure
- Excellent solution for highly corrosive, toxic or valuable media applications
- Can be used as triggered, fast-opening valve

APPLICATIONS

The most common application for a double disc assembly is to protect the primary bursting disc from high back pressure. This condition can occur when multiple bursting disc assemblies, protecting multiple processes, discharge into a common header. If one bursting disc assembly bursts, the resulting discharge into the common header could subject the remaining bursting disc assemblies to a transient elevated back pressure condition. The SCRD-V bursting disc is commonly used as the secondary disc in a

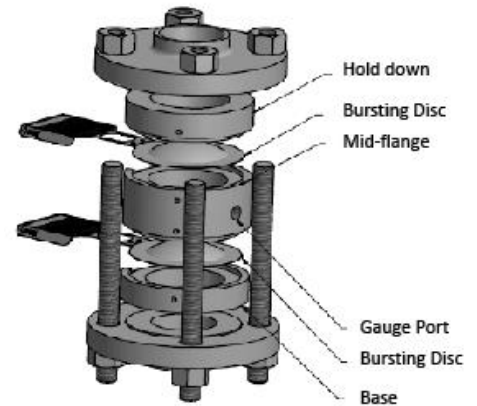

APPROVALS:

- CE
- UD



DD assembly to withstand potential back pressure events. The standard SRL and SCRD-V DD are designed for one atmosphere back pressure capability. Consult the factory if a back pressure greater than one atmosphere is required.

To ensure proper operation of any double disc assembly, the mid-flange must be equipped with a means to guarantee the space between the primary and the secondary discs remains at atmospheric pressure. Pressure must not be allowed to accumulate above atmospheric pressure in the mid-flange volume as this will result in a significant increase in inlet pressure necessary to cause the primary disc to burst, thereby compromising the safety of the system.

Environments involving corrosive, toxic or valuable media may be acceptable applications for the double disc assembly. A double disc assembly can help contain any leakage through the primary disc (caused by fatigue, sulfide stress cracking, or corrosion) and will be captured by the secondary disc. In addition to maintaining atmospheric pressure in the mid-flange volume, it is recommended that a sensing device is installed in the mid-flange to provide immediate notice that replacement is needed should leakage develop through the primary disc. When leakage is detected an immediate replacement is advised.

For more information on use of Double Disc Assemblies, please refer to 8.0124.00.x (technical bulletin).

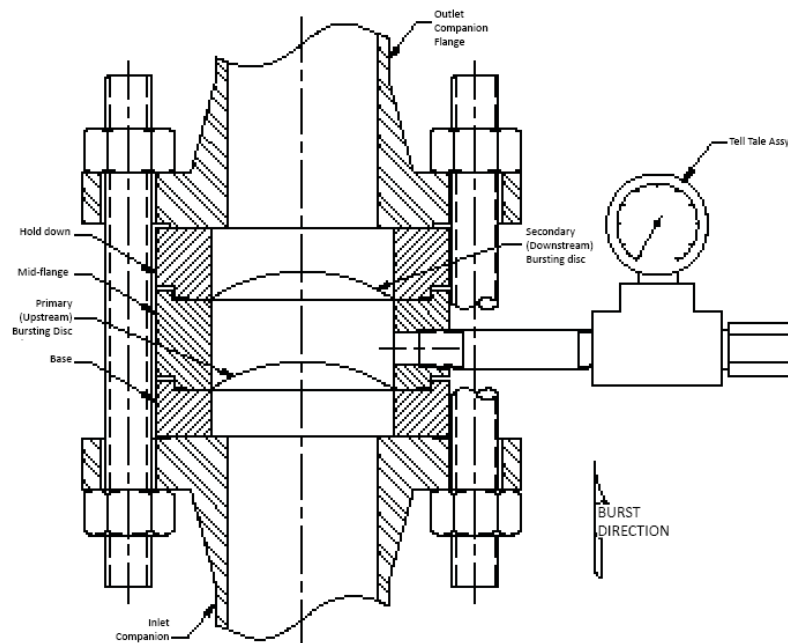



AVAILABLE (CERTIFIED) BURST PRESSURE FOR POLY-SD AND SCRD-V DD IN BARG @ 22°C

Size		Minimum BP (barg)				Maximum BP (barg)
IN	DN	316 SST	Inconel 600	Monel 400	Nickel 200	All
2	50	10.89	9.10	8.27	7.31	110.32
3	80	10.89	9.10	7.31	5.17	89.63
4	100	9.17	7.31	5.93	4.62	75.84
6	150	6.62	5.17	5.17	3.45	34.47
8	200	5.17	3.79	3.79	2.07	31.03
10	250	4.14	3.03	3.03	1.65	27.58
12	300	3.45	2.55	2.55	1.38	24.13
14	350	2.96	2.21	2.21	1.17	20.68
16	400	5.86	4.41	4.41	2.07	17.24
18	450	5.17	3.79	3.79	1.72	13.79
20	500	4.48	3.45	3.45	1.72	10.34
24	600	3.79	3.10	3.10	1.38	6.89

For other burst pressures, consult factory.

AVAILABLE (CERTIFIED) BURST PRESSURE FOR SRL DD IN BARG @ 22°C

	316 / 316L SST	Inconel 600	Nickel 200/201	Hastelloy C276					
Max. Temp	482°C	593°C	427°C	482°C					
Size	Burst Pressure								
In	DN	Min	Max	Min	Max	Min	Max	Min	Max
1	25	3.45	18.97	3.45	10.69	2.07	5.86	4.14	22.07
1.5	40	3.45	18.97	3.45	10.69	2.07	5.86	4.14	22.07
2	50	17.72	15.86	1.72	12.41	1.24	5.17	3.10	18.28
3	80	1.52	13.10	1.52	10.34	1.03	4.14	2.76	13.79
4	100	1.38	12.41	1.38	10.34	0.83	3.45	2.41	11.03
6	150	1.24	10.34	1.24	10.34	0.69	3.45	2.21	7.93
8	200	1.17	9.31	1.17	8.97	0.69	4.83	2.07	7.93

Performance Attributes				Process Media			Holders	
Operating Ratio	Non-fragmenting	Vacuum Resistance	Pulsating / Cycling	Polymerisation	Liquid	Vapour / Gas	Bolted	Pretorqueable
95%	Yes	Yes	Yes	Yes	Yes	Yes	Yes	Yes